



# Rail System 4000 User Manual

## New Product & Part Sales

Rail Alignment  
19000 W 158th  
Olathe KS 66062  
913 334 8439

## Warranty Service Center

Laser Specialists  
19879 W 156<sup>th</sup>  
Olathe KS 66062  
913 780 9990

Copyright 2016  
Rail Alignment LLC  
Olathe KS 66062  
Version 3, Rev A-May16

Rail Alignment ©  
Olathe Ks 66062  
913 334 8439  
[www.RailAlignment.com](http://www.RailAlignment.com)

## **Table of Contents**

|                                 |              |
|---------------------------------|--------------|
| <b>Component Specifications</b> | <b>3</b>     |
| <b>Set-up</b>                   | <b>4-15</b>  |
| Component Layout                | 4-5          |
| Peripheral Cables               | 5-6          |
| System Function Check           | 6-7          |
| Motor Lead Orientation          | 7            |
| Limit Switch Orientation        | 7            |
| Servo/Sensor Setup              | 8-11         |
| Sensor Ground Strap             | 12-13        |
| Panel Ground Strap              | 14-15        |
| Buggy/Cart Setup                | 16-17        |
| System Deployment               | 18-19        |
| <b>Component Breakdown</b>      | <b>20-66</b> |
| RS4000 Panel                    | 20-25        |
| RS4000 Lightbar                 | 26-31        |
| RS4000 Sensor                   | 32-35        |
| RS4000 Laser/Cannon             | 36-43        |
| RS4000 Tripod/Laser Mount       | 44-45        |
| RS4000 Laser Cart/Buggy         | 46-47        |
| RS4000 Solar Cart/Buggy         | 48-50        |
| RS4000 Plasser Servo Assembly   | 51-55        |
| RS4000 Jackson Servo Assembly   | 56-62        |
| RS4000 Cannon Servo Assembly    | 63-69        |
| <b>Trouble Shooting</b>         | <b>70-72</b> |
| <b>Warranty</b>                 | <b>73</b>    |
| <b>Care and Transport</b>       | <b>74-75</b> |
| Calibration                     | 74           |
| Transportation                  | 74           |
| Storage                         | 74           |
| Cleaning and Drying Windows     | 74           |
| Maintenance                     | 74-75        |
| <b>Safety Direction</b>         | <b>75-76</b> |
| Laser Classification            | 75           |
| FCC Statement                   | 76           |
| <b>Copyright Information</b>    | <b>76</b>    |

# Rail System 4000 Component Specifications

## RS4000 24VDC Panel---Part # 40500

Input Power Requirements: 24 VDC +/- 2 VDC

## RS4000 127-150VAC Panel---Part # 40504

Input Power Requirements: 127 to 150VAC +/- 2 VAC

Sensor Power Output: +12 VDC & -12 VDC

Servo Power Output: 24 VDC

Lightbar Power Output: 12 VDC

Dimensions: Weight: 14 lbs (6.35kg), Height: 6.38" (16.2cm), Width: 11.5" (29.2cm),  
Length: 13.75" (34.9cm)

Note: The updated RS4000 Panels are not backward compatible with the late model Sensor or Lightbar. If you replace a late model Panel with the updated RS4000 Panel, you must also replace your late model Sensor and Lightbar. **WARNING: Using a Halogen Lightbar with the 40500 or 40504 Panel can result in catastrophic damage to the panel.**

## RS4000 Lightbar---Part # 40510

Input Power Requirements: 12 VDC (supplied by the Panel)

Dimensions: Weight: 21.5 lbs (9.75kg), Height: 3.5" (8.9cm), Width: 6.75" (17.1cm),  
Length: 60.25" (153cm)

Note: The updated RS4000 Lightbar is compatible with the late model panels. The updated 40510 Lightbar is required for use with the 40500 Panel.

## RS4000 Sensor---Part # 40520

Input Power Requirements: +12 VDC & -12VDC (supplied by the panel)

Center Range: .25" (6.4mm) from center

Sensor Detecting Range: 20' to 2000' + (6m to 610m)\*

Dimensions: Weight: 10.75 lbs (4.88kg), Height: 3.25" (8.2cm), Width:  
11.25" (28.5cm), Length: 6.75" (17.1cm)

Note: The updated RS4000 Sensor is not backward compatible with the late model Panel. If you replace a late model Sensor with the updated 40520 Sensor, you must also replace your late model Panel and Lightbar. **\*Sensor Detection Range is affected by multiple environmental conditions and may vary.**

## RS4000 Laser/Cannon---Part # 40530 & 40533

Input Power Requirements: 12 VDC +/- 2 VDC

Beam Deflection: 1% from center or 1' per 100' (1m per 100m)

Minimum Output Power: 1.8 mW on SP401 meter

Beam Size: .8" at 20' (20mm at 6m) 2"-4" at 2000' (50-100mm at 610m)

Focal Distance: 300' (91m)

Sweep Rate: 10-15 pulses per second

Dimensions: Weight: 9.25 lbs. (4.2kg), Height: 6" (15.2cm), Width 3"  
(7.6cm), Length: 26.5" (67.3cm)

## RS4000 Setup

Before you install the RS4000 system, check to ensure that nothing was damaged or lost during shipping.

If anything is damaged or missing, contact your salesman immediately.

### Mount Components

The Rail System 4000 is intended for use with several different models of equipment. Each piece of equipment will accommodate this system differently. This section of the manual is intended to be a general guide and is not specific to any one manufacturer.

#### RS4000 Panel

The Panel assembly is generally mounted on the large deployable buggy provided with the tamper. The Panel comes with a universal mounting kit that has multiple mounting positions. Choose the right location for your specific equipment that will allow easy access to the RS4000 Panel and will also allow the cables to be routed to the peripheral components without issue.

#### RS4000 Lightbar

The Lightbar assembly is generally mounted toward the front of the large deployable buggy provided with the tamper. It would be helpful to mount the Lightbar up high and as far forward on the buggy as possible. Ensure that nothing will be blocking the lights on either side of the Lightbar when the system is in operation. The five small round indicators should face the tamper operator when properly installed. Installation of the Universal Lightbar Mount, may not require all of the pieces provided.

**IMPORTANT: Ensure that the rubber isolators used in the mounts are perpendicular with the Lightbar once everything is installed.**

#### RS4000 Sensor and Servo

The RS4000 Sensor is mounted directly to the top of the Servo that is used with your specific brand tamper. Any questions regarding how or where the Servo is installed should be referred to the tamper manufacturer.

## RS4000 Buggy

The RS4000 aluminum Buggy will need to be unpacked and partially assembled. New from the factory the Buggy will not have the wheel/axle or the bias clamp assemblies installed. Those items, along with a Flag, Battery Box and Handle, will be located in the shipping box with the Buggy frame. (Buggy setup is laid out in the 'Setup' section of this manual.)

## RS4000 Tripod

The Tripod assembly gets installed onto the RS4000 Buggy. Ensure that the Tripod is oriented on the Buggy so that the red pointer, located at the bottom rear of the front mount clamp, is on the same side of the Buggy as the offset scale. (Tripod setup is laid out in the 'Setup' section of this manual.)

## Route and Install Peripheral Cables

Locate and un-box the cable set that was supplied with the RS4000 Panel.

**Panel Power** –Locate the power cable for the Panel. This will either be Part Number 40046 (3-Pin), Part Number 40255 (6-Pin) or Part Number 40295 (5-Pin) depending on how your system was configured. The connector end of the cable plugs into the bottom of the Panel in location "C" of the Panel Connection Diagram. Run the cable along the frame of the buggy back to the power source (**24VDC for Panel Part Number 40500 and 127-150VAC for Panel Part Number 40504**).

### 40046 Pin Out

White = Power  
Black = Ground

### 40255/40295 Pin Out

Red = Power  
Black = Ground  
Yellow = Toggle Left  
Brown = Toggle Ground  
Blue = Toggle Right

Once the power cable is energized, turn the Panel on and ensure that it powers up. If the Panel does not turn on, troubleshoot before moving on to the next step.

**IMPORTANT: If your system was configured with Power Cord Part Number 40255 or 40295 but you are NOT using an external pendant to control Servo position, DO NOT REMOVE THE INSULATORS FROM THE ENDS OF THE YELLOW, BROWN AND BLUE WIRES DURING INSTALLATION.**

**Limit Switches** – Locate the two limit switch cables, Part Number 40047. Mount the limit switches to the mount plates on the servo using the hardware provided with the Servo assembly (located in cloth bag tied to the Servo). The connector ends of the limit switch cables plug into the bottom of the Panel in locations E and F of the Panel Connection Diagram.

**Lightbar Cable** – Locate the Lightbar cable, Part Number 40048. Plug the appropriate connector into the Lightbar. The connector on the opposite end of the cord plugs into the bottom of the Panel in location A of the Panel Connection Diagram. **NOTE:** This cable has similar 8 pin connectors on both ends. One is male and one is female. Ensure that the correct end is being connected to the intended components.

**Servo Power** – Locate the Servo motor power cable, Part Number 40049. Connect the bare cables to the terminal block with one of each of the two wires located across from one of each the wires from the motor. The connector plugs into the bottom of the Panel in location D of the Panel Connection Diagram.

**Sensor Cable** – Locate the Sensor cable, Part Number 40050. Plug the appropriate connector into the Sensor. The connector at the opposite end of the cord plugs into the bottom of the Panel in location B of the Panel Connection Diagram. **NOTE:** This cable has similar 8 pin connectors on both ends. One is male and one is female. Ensure that the correct end is being connected to the intended components.

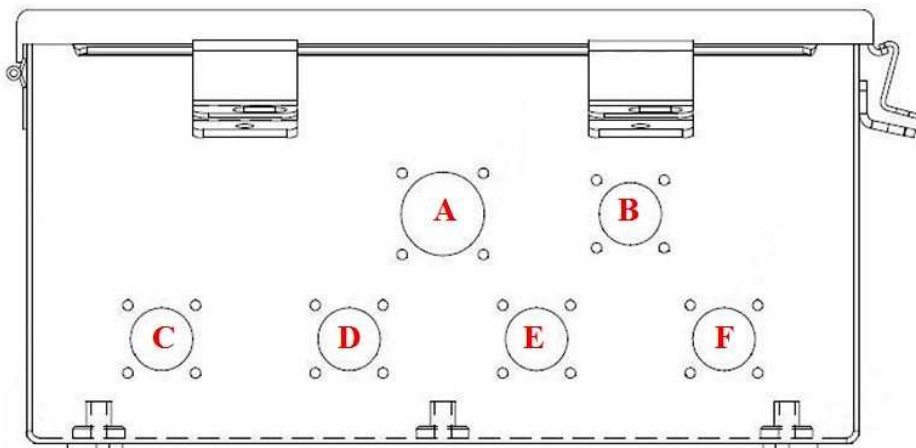

**Panel Connection Diagram**

## **System Functions Check**

**Lightbar** – Turn the Panel on and observe that each of the three high output LED lights on the Lightbar flash in sequence. To check the red limit indicators, have someone activate each of the two limit switches located on the Servo assembly. If the Lightbar does not appear to turn on, troubleshoot before moving on to the next step.

**Servo Motor** – Check to ensure that the Servo motor is responding. To do this use the Left/Right motor control switch on the face of the Panel. Ensure that a response is received for both directions. If the Servo does not appear to turn on, troubleshoot before moving on to the next step.

**Sensor** – Check to ensure that the Sensor is watching for an input and communicating back to the Panel. To do this, use the Laser Simulator that was provided with the Sensor. Ensure that the Panel is in Standby mode. Place the Simulator up to the window of the Sensor (output Diode toward the window). Activate the Simulator by pressing the red button on the housing. Move the Simulator back and forth across the window of the Sensor and observe that both the lights on the Lightbar and the Panel are indicating an input from the Simulator. If the Panel and Lightbar do not respond to the sensor, troubleshoot this before moving on to the next step. Note: To ensure that the Simulator is functioning properly, simply look at the output diode while activating it. You should see a red flashing light being emitted from the diode.

**Motor Lead Orientation** – It is possible that the leads for the Servo motor were oriented backwards when the initial connections were made. It is simple and necessary to check.

Place the Panel in Automatic mode. Place the Laser Simulator in front of the window of the Sensor and move it to either of the outside edges. Activate the Simulator causing the Servo Assembly to start moving. **DO NOT MOVE THE SIMULATOR WITH THE SERVO.** Instead observe that the Sensor is trying to center on the Simulator. If you are holding the Simulator to the right side of the Sensor window, the Servo should be traveling to the right. If the Servo is traveling to the left, then the leads to the Servo motor are backwards and need to be reversed.

**Limit Switch Orientation – (Do this step only after you have completed the Motor Lead Orientation check above.)** It is possible that the limit switches were oriented backwards during the initial setup. It is simple and necessary to check.

Place the Panel in Automatic mode. With the Laser Simulator in hand, orient yourself around the Servo assembly so that you can reach the front of the Sensor and both limit switches. Place the Laser Simulator against the window of the Sensor and move it to either of the outside edges. Activate the Simulator causing the Servo Assembly to start moving. Active which ever limit switch the Servo is moving **toward** and ensure that the Servo travel stops.

When the limit switch is released, the Servo travel should start again. If the limit switch that the Servo is traveling toward does not stop the Servo when it is activated, then the switches are probably REVERSED. Quickly check to see if the other switch causes the Servo to stop. If the switches are backward, simply disconnect the connections on the bottom of the panel in locations E and F and reconnect them in the opposite locations.

## Servo/Sensor Setup

**IMPORTANT:** Find and mark a section of level track with good gauge. Place the front of the Buggy with the Servo on that section of track. This same section of track will be used to setup the laser cart in a later step.

Turn on the power to the Rail System 4000.

Remove the vandal cover from the RS4000 Receiver and place it out of harms way (not on top of the Receiver for this process).

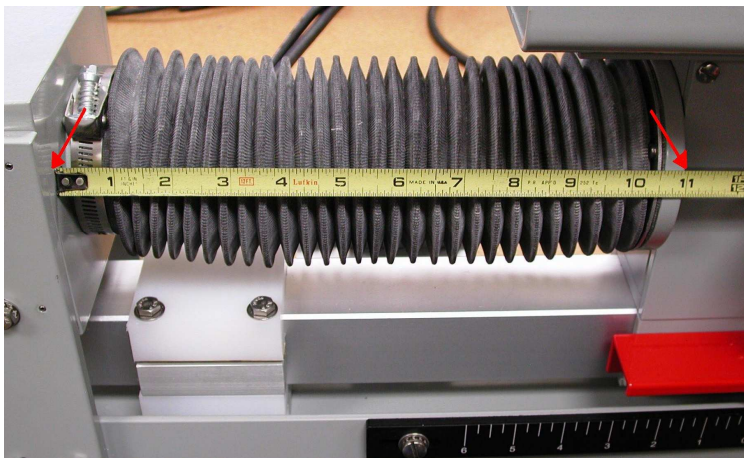

Center the Servo assembly by using the Left/Right toggle switch on the RS4000 Control Panel. Using the mounting points for the flexible shields (indicated by the Red arrows in the picture to the left) on the servo as a reference, measure to verify that the distance on both sides is equal. The

measurement should be roughly 10 7/8" – 11" on both the left and right side of the Servo assembly.

Next, set pre-load tension spring or the reference/bias wheel for which ever rail you are going to start with.

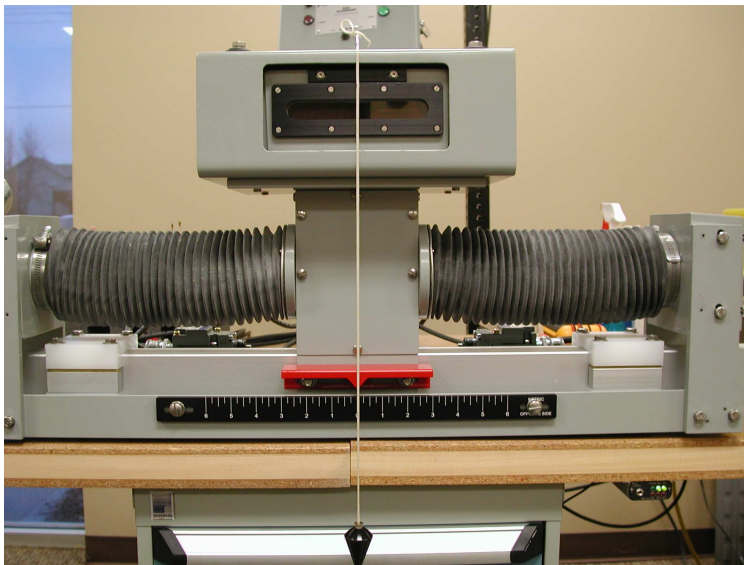

Next, tie a plumb bob to the lock stable on the top of the sensor mount. Align the string so that it is hanging directly through the center of the calibration plate on the face of the Sensor assembly as pictured to the left. Ensure that the string hangs far enough down to align the pointer and scale also.



**NOTE: If you have not chosen level track, the measurement off of the plumb bob may not be accurate. Level track is critical for this process.**

Measure from the Reference Rail to the string and record the measurement. Next move the Servo Platform to the opposite rail and ensure that the string is above center mark. Measure from the gauge side of the opposite Reference rail to the string and record the second measurement. The two measurements should be the same, if not split the difference.

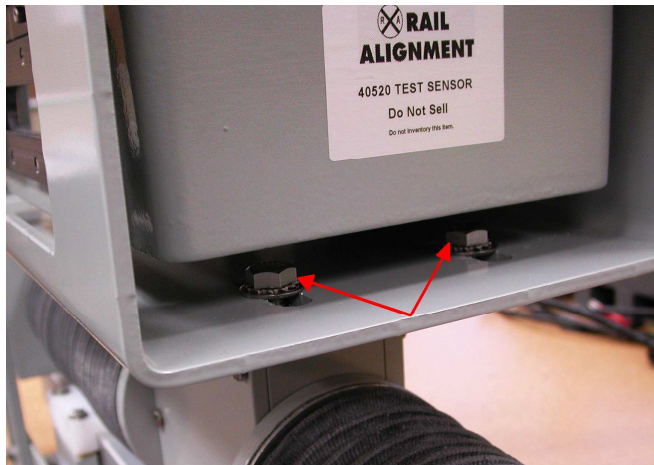

For example, if one side is 28" and the other is 27 3/4", then you would move the whole Sensor assembly in its mount in the proper direction to achieve a measurement of 27 7/8" from the plumb bob to either rail. Photo to the left shows the location of two of the four bolts that hold the Sensor Mount.

**NOTE: In this example, record the 'final measurement' of 27 7/8" as it will be used to set up the laser cart later.**

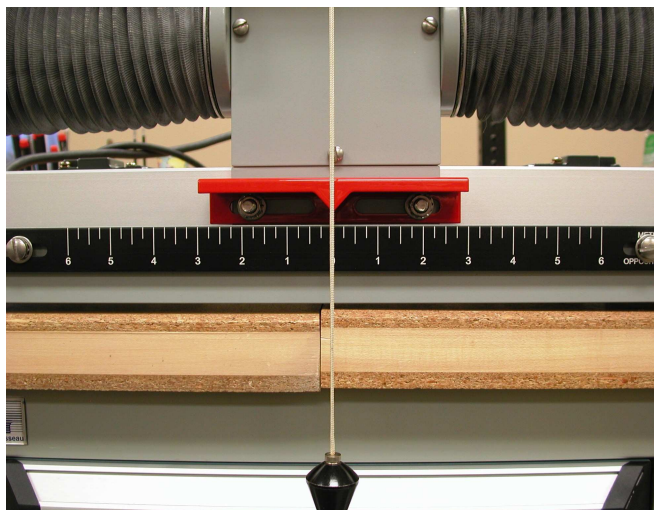

Adjust the pointer and scale so that the string runs through the center (Zero) of both pieces.

Confirm that the string is still running through the center of the calibration plate on the Sensor as you do this process.

## **WARNING:**

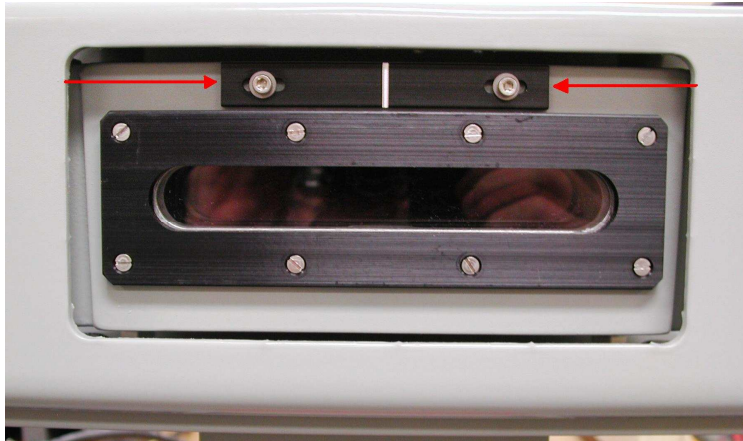

The calibration plate between the two red arrows in the picture to the left is set at the factory for each specific Sensor assembly. This plate may not be in the same exact position for each individual Sensor. However,

unless someone has changed the position of the plate or the Sensor is malfunctioning, it correctly indicates the true center for that specific Sensor and should not be changed.

**Do not attempt component calibration. Calibration should be performed only by a qualified individual that understands basic calibration principles.**

**If you feel that your Sensor is not correctly calibrated, send it in for adjustment.**

## Replacement Sensor Installation and Adjustments

When installing a secondary/replacement sensor into a system, it is necessary to double check the alignment of the replacement Sensor to the center of the Servo assembly.

The process is simple. String a plumb bob through the center line on the calibration plate. If the plumb bob and string line up through the center of the pointer (bottom of Servo directly above the scale), then no adjustments are needed.

If the plumb bob and string do not line up through the center of the pointer, then you must move the whole Sensor Mount in the necessary direction to align the pieces.

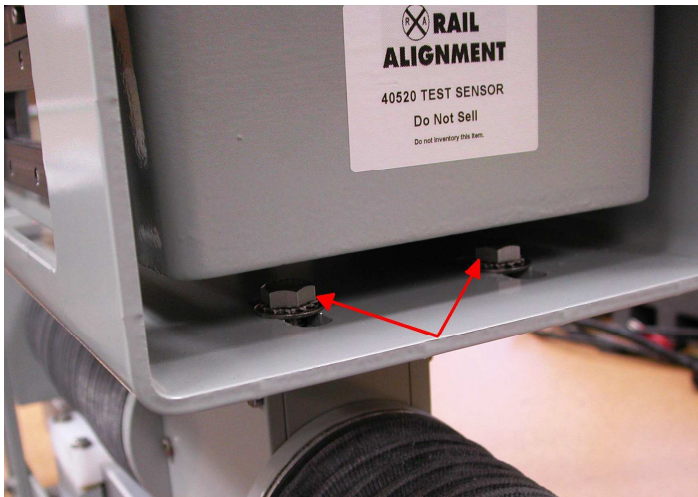

Loosen the four hex head bolts located on the bottom of the sensor mount directly below the Sensor. You can access two from each end of the mount opening as pictured to the left. With the bolts loose, move the sensor mount left or right as required to properly align the Sensor to the system. A 9/16" wrench is required to make the adjustment. Once the Sensor is properly

centered, tighten the four hex head bolts.

**The RS4000 Sensor and Servo are properly set up and ready for use.**

## Ground Straps

In early 2011 we determined that our electronics would benefit from the addition of a ground strap on both the Panel and Sensor. We have been providing ground straps with our systems since Mar of 2011. If your system doesn't currently have ground straps on it, you can purchase them as a spare part and install them if desired. Below is all the information that you will need.

### ***Sensor Ground strap kit includes:***

Qty 1, 9" Braided Ground Strap (Part # 40288)

Qty 1, 5/16-18 x 1 1/4" Hex Cap Screw

Qty 1, 5/16" Internal Tooth Lock Washer

Tools needed for install:

1/2" and 9/16" Wrenches



If you are installing a ground strap onto an existing system, you will need to remove the sensor from its mount first (1/2" wrench). Then remove the right rear (as you are facing the servo and sensor) bolt and washers from the inside of the sensor mount (9/16" wrench). Remove the flat washer from the bolt, leaving the ext. tooth lock washer. Put the bolt through one end of the ground strap and then reinstall the flat washer. Install the bolt through the mount and back into the servo. Tighten the bolt with a 9/16" wrench ensuring that the strap is hanging straight out of the side of the sensor mount.



Next, install the sensor into the mount. Use the 5/16-18 x 1 ¼" Bolt provided with the kit to hold the strap in right rear position of the sensor as pictured above. Install the 5/16" internal tool lock washer onto the bolt, then the strap, then the flat washer that was originally provided. Tighten all four mounting bolts using a 1/2" wrench.



Once the strap is installed correctly, the assembly should look like the photo to the left.

**Panel Ground strap kit includes:**

Qty 1, 5" Braided Ground Strap (Part # 40287)

Qty 2, 1/4" Internal Tooth Lock Washer

Tools needed for install:

7/16" Wrench

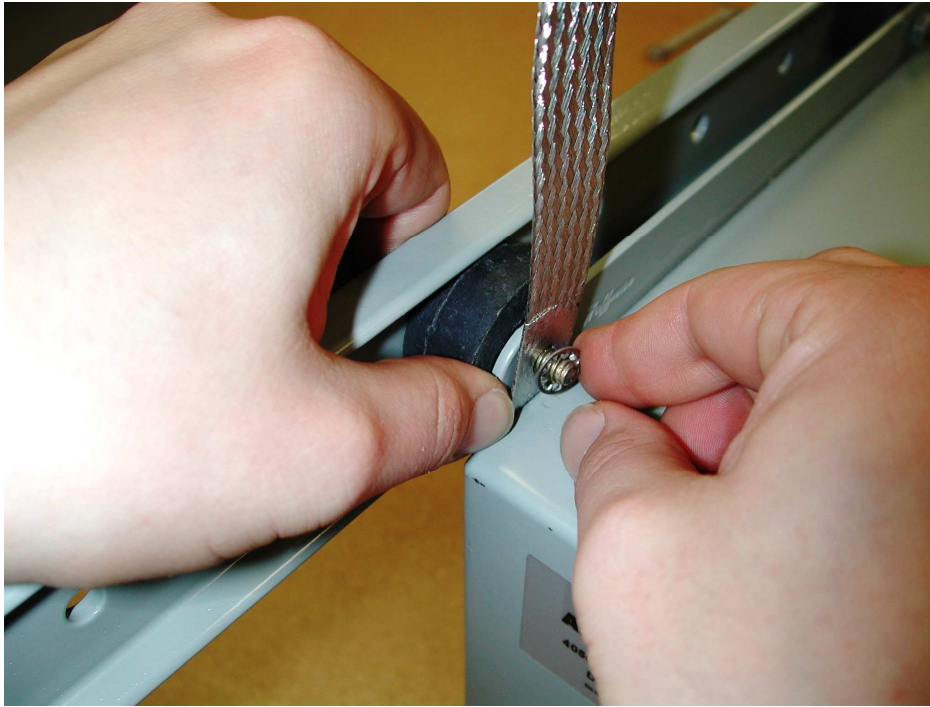

The ground strap for the panel is meant to ground the metal case of the panel to the metal mount that is attached to the front buggy of the tamper. It is recommended that any paint underneath where the strap will be installed be removed for best results. Choose any rubber mount in the corners of the panel. Remove the nylon lock nut from the panel side. Place the ground strap on the stud, then the 1/4" int. tooth lock washer and then replace the lock nut. Tighten the nut with a 7/16" wrench.

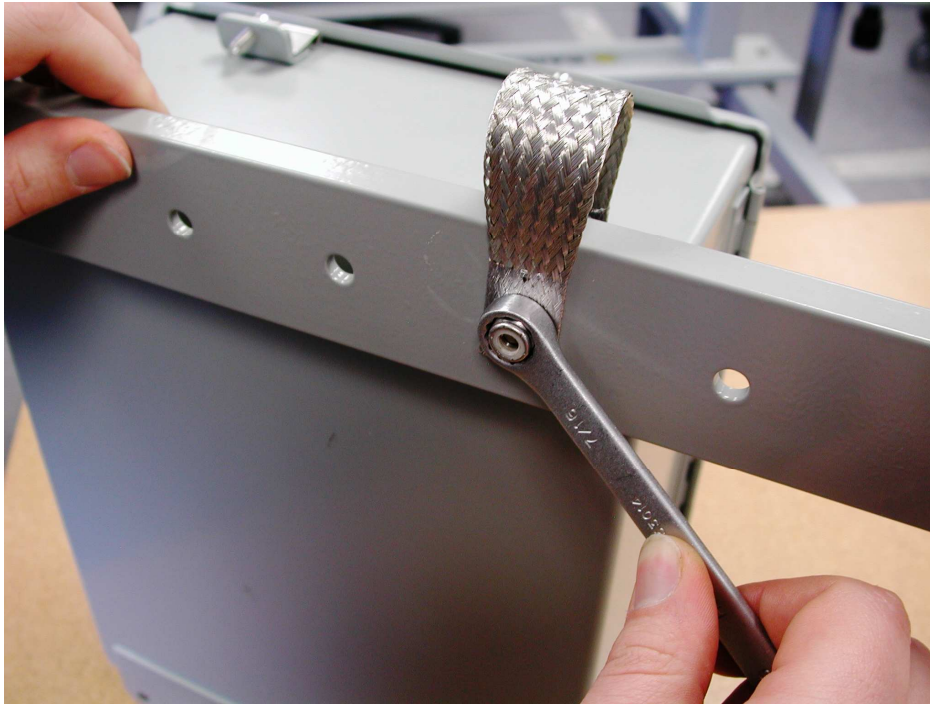

Next, remove the nylon lock nut off the back of the mount bar. Loop the ground strap over the bar from the front of the panel and land it on the stud. Place the second 1/4" internal tooth lock washer on the stud and then reinstall the nylon lock nut. Tighten the nut with a 7/16" wrench.

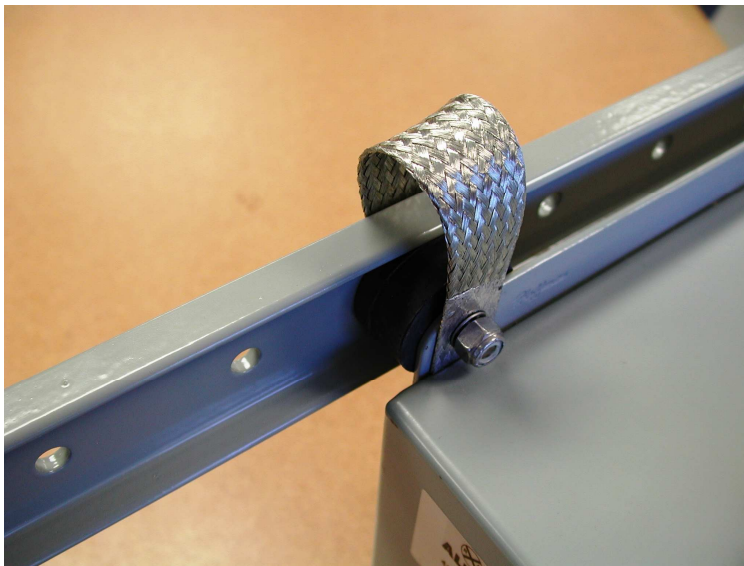

Once the strap is installed correctly, the assembly should look like the photo to the left.

## Buggy/Laser Cart Setup

When setting up a brand new Buggy, you will need to insert the wheel/axel assemblies into the four mounting positions on the bottom corners of the buggy.

Find a section of level track with good gauge. Place the Buggy on that section of track.

If the Laser Tripod is mounted on the Buggy, it will need to be removed before you can proceed (old Buggies).

Measure the width of the Buggy across the top of the frame where the Tripod would normally be sitting (Should be approximately 51 ½"). Make a pencil mark in the center of the frame (approximately 25 ¾"). Measure and mark the rear bar of the buggy also.

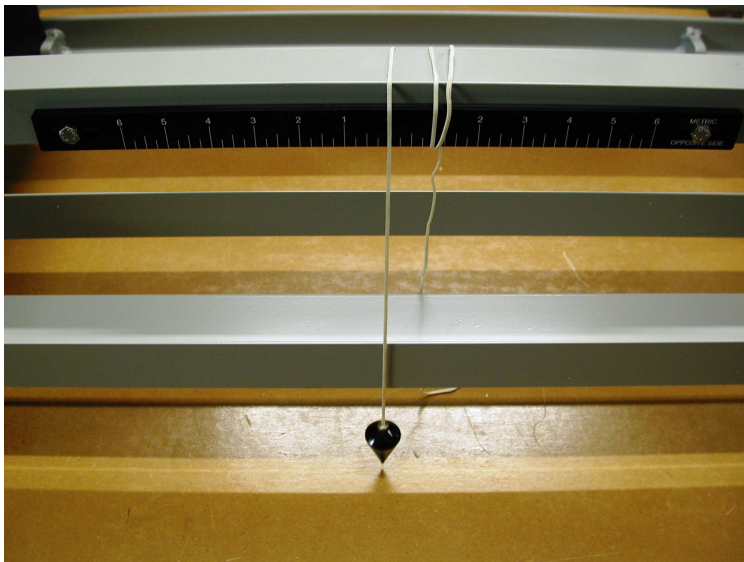

Tie a plumb bob on the center mark that you measured and marked.

Ensure that the offset scale is 'Zeroed' to the center mark at this point.

Measure the width of the track from the inside of the 'ball' on one side to the inside of the ball on the opposite side. Mark the center of the measurement on a tie below the Buggy.

Move the front of the Buggy with the plumb bob attached and hanging from your center mark over the center mark on the tie. Move the Buggy left or right as required to position the center of the Buggy over the center of the track. **NOTE: Only worry about the front of the Buggy at this point since that is where the plumb bob is located.**

With the Buggy centered, move the wheel/axel assemblies on the front of the Buggy out to the 'ball' of the track. Double check that the Buggy is still properly centered after you move the wheels. Tighten the set screws with a 3/16" allen wrench.



Move the back of the Buggy up to the tie with your center mark for the track. Move your plumb bob to the center mark on the back of the buggy and repeat the procedure again.

Once both the front and rear of the buggy have been centered it is a good idea to check everything a second time just to be sure.

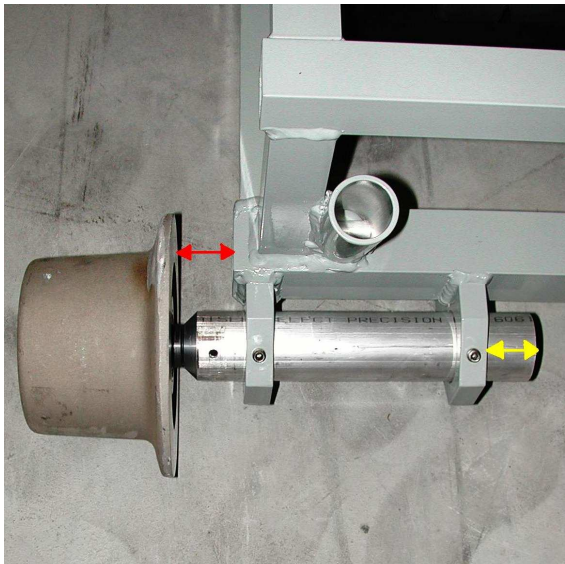

After you have set the wheel/axle assemblies there are a couple of places on each wheel that you can measure to help ensure that the Buggy is set up properly. Measure between the back of the wheel and the frame (red arrow) or measure the amount of the axle that is protruding from the axle mount (yellow arrow). All four assemblies should read very close to the same measurement.

**If you find that the four assemblies are not measuring out to be in the same position, it is very possible that the Buggy is not correctly set up. It is recommended that you repeat the setup procedure again.**

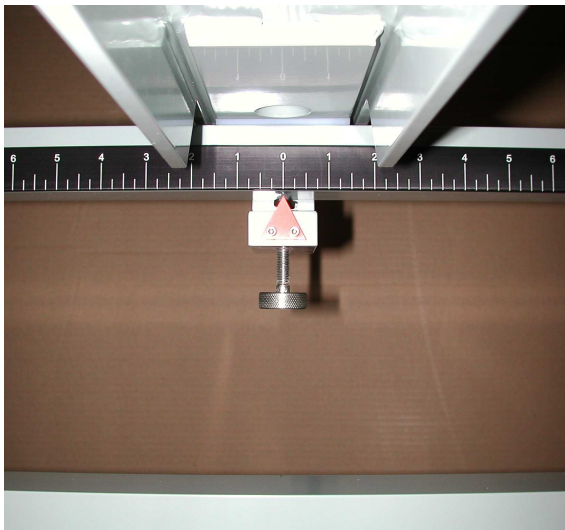

Install the Tripod back onto the Buggy. Ensure that the offset indicator located on the bottom front of the Tripod is 'Zeroed' before securing the Tripod to the buggy.

**The RS4000 Buggy and Tripod are properly set up and ready for use.**

## **Deploying the RS4000 System for Use**

**The following instructions are for a typical set up when tamping existing track. If no offset is required, both the Sensor and the Laser should be positioned at a 'Zero' setting on the offset scales. If an offset is required, make the appropriate adjustments at this point.**

Remove and secure the Vandal Covers from the RS4000 Panel and Sensor. Turn the Panel power on and ensure it is in 'Standby' mode.

With the Buggy/Laser Cart lowered down and setting on the track, place the Cannon/Laser into the Laser Mount on the Buggy with the Laser pointing toward the tamper. Place a fully charged deep cycle 12 Volt battery into position in the bottom of the Buggy.

Push the Buggy ahead of the tamper to the desired distance. Working distance will vary depending on equipment condition, proper set up, and environmental conditions. It is possible to achieve working distances of more than a half mile with the new RS4000 systems.

Make sure the Buggy is on a track with good line. It may be set at the beginning of a curve or at the edge of a fixed obstruction. If working in an area with multiple lines of track, keep in mind proper clearances and measure track centers . Secure the Buggy to the line rail that the tamper is set up for using the clamp assembly that is on the Buggy.

Connect the battery leads from the Key Box cable to the deep cycle battery in the bottom of the Buggy. Then plug the Laser into the Key Box cable. Ensure that the Laser is emitting a beam.

Level the Laser by rotating it left or right in the Tripod cradles until the bubble in the level vial is centered (level vial located on the rear of the Laser above the power cable).

Aim the Laser toward the Receiver by adjusting the vertical and horizontal position with the Tripod until one of the three indicator lights on the Lightbar is activated. The two outside indicators on the Lightbar are Amber and indicate that you are on one of the outside edges of the Sensor. The center indicator is White.

Adjust the Laser using the Tripod until you get the center white indicator to activate.

When the center white light on the Lightbar starts flashing continuously, the Laser is 'Zeroed' on the Receiver and the system can be placed into Automatic mode.

With the system in automatic mode, watch for a few seconds to ensure that the Sensor remains locked onto the Laser and hold its position. If it holds, the system is ready for use. If the receiver moves in one direction more than  $\frac{1}{4}$ " (Running), then the system is not correctly 'Zeroed'. Switch the system back into Standby mode, manually re-center the Servo using the 'Left/Right' switch on the Panel and repeat the Zeroing process.

**With the RS4000 system properly set up, you are ready to begin tamping.**

## RS4000 Component Breakdown

### RS4000 Panel Kit---Part # 40600 & 40604

40600---24VDC Panel Kit  
40604---127-150VAC Panel Kit

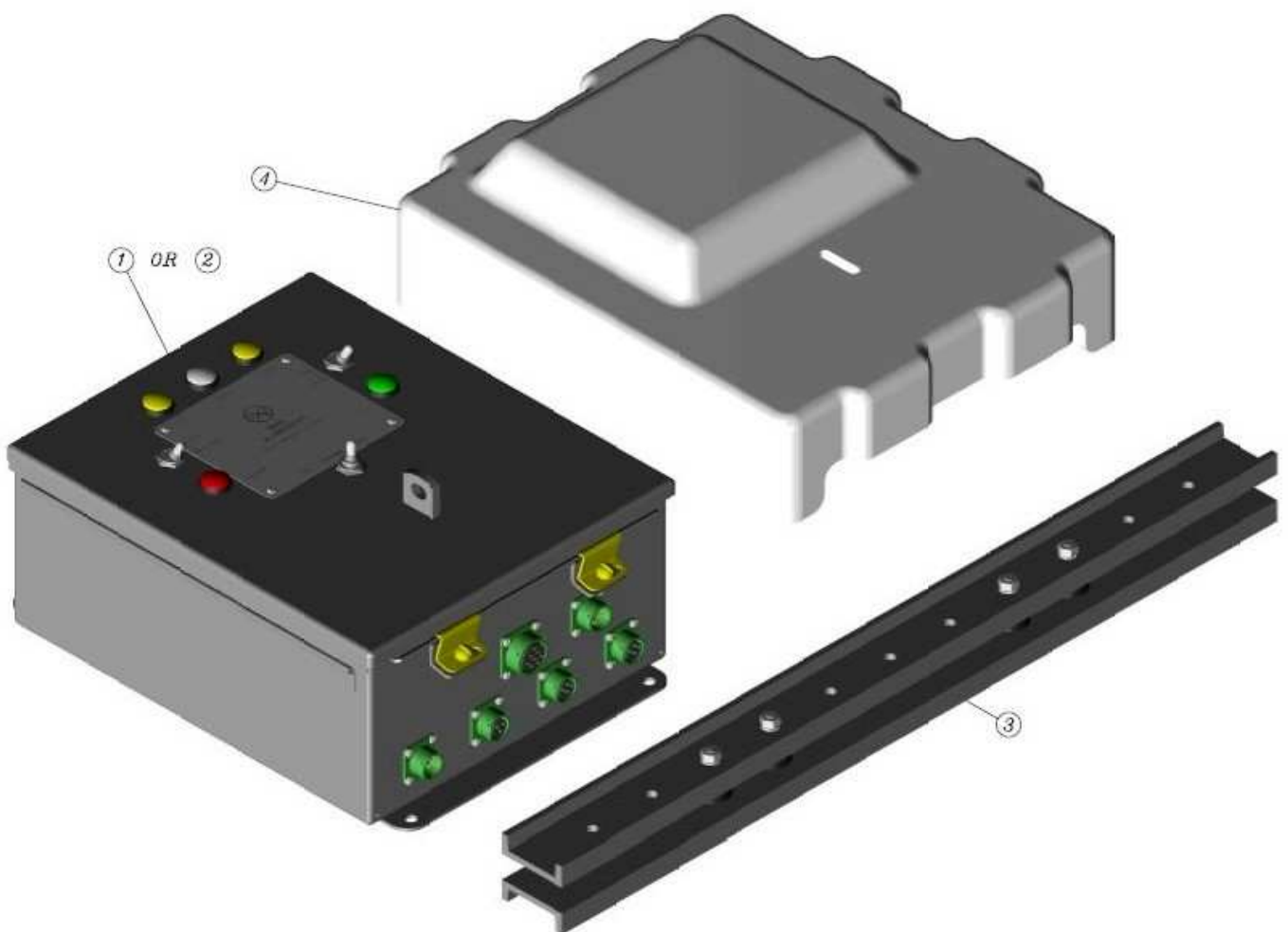

## 40600 & 40604 Parts List

| Item No.       | Part Number | Description                      |
|----------------|-------------|----------------------------------|
| 1              | 40500       | RS4000 24VDC Panel Assembly      |
| 2              | 40504       | RS4000 127-150VAC Panel Assembly |
| 3              | 40501       | Panel Mounting Kit               |
| 4              | 40503       | Vandal Cover                     |
| Not Pictured** | 40502       | Panel Cable Set                  |

### **\*\* Cable Set includes the following items:**

| Quantity | Part Number   | Description       |
|----------|---------------|-------------------|
| 1        | 40295 (5-Pin) | Panel Power Cable |
| 1 Alt    | 40255 (6-Pin) | Panel Power Cable |
| 1 Alt    | 40046 (3-Pin) | Panel Power Cable |
| 2        | 40047         | Limit Cable       |
| 1        | 40048         | Lightbar Cable    |
| 1        | 40049         | Servo Power Cable |
| 1        | 40050         | Sensor Cable      |

# RS4000 Panel---Part # 40500

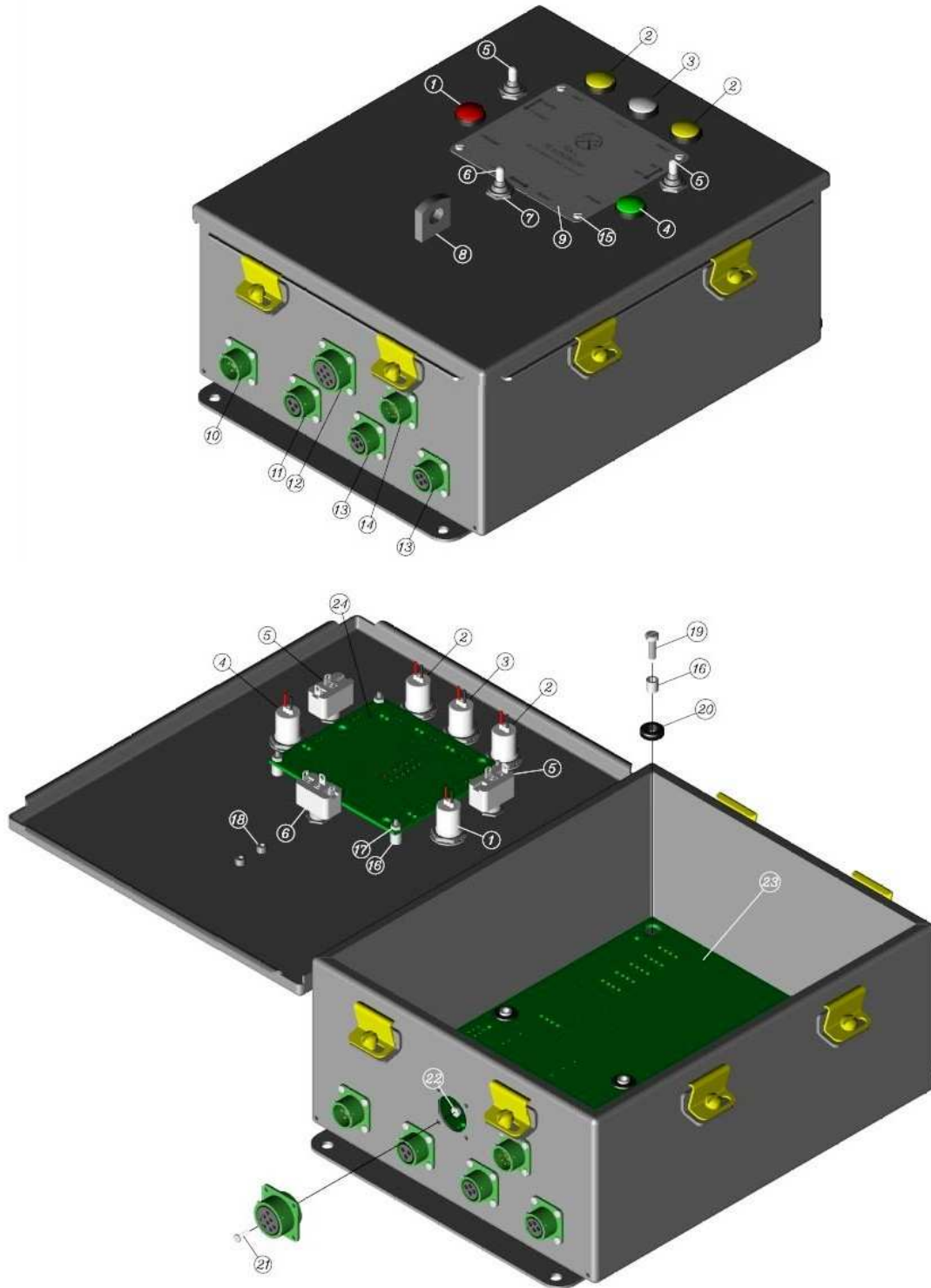

## 40500 Parts List

| Item No. | Part Number   | Description                          |
|----------|---------------|--------------------------------------|
| 1        | 40016         | Red LED Standby Indicator*           |
| 2        | 40019         | Yellow LED L/R Indicator*            |
| 3        | 40018         | White LED Center Indicator*          |
| 4        | 40017         | Green LED Power Indicator*           |
| 5        | 40036         | On/Off & Standby Toggle Switch       |
| 6        | 40037         | Left/Right Toggle Switch             |
| 7        | 40038         | Toggle Switch Boot*                  |
| 8        | 743790        | Lock Stable*                         |
| 9        | 40058         | Face Plate*                          |
| 10       | 40294 (5-Pin) | Power Connector w/ Wiring Harness    |
| 10 Alt   | 40254 (6-Pin) | Power Connector w/ Wiring Harness    |
| 10 Alt   | 40179 (3-Pin) | Power Connector w/ Wiring Harness    |
| 11       | 40178         | Servo Connector w/ Wiring Harness    |
| 12       | 40176         | Lightbar Connector w/ Wiring Harness |
| 13       | 40177         | Limit Connector w/ Wiring Harness    |
| 14       | 40175         | Sensor Connector w/ Wiring Harness   |
| 15       | Ref Only      | 4-40 x 3/4" Phillips Pan Head Screw  |
| 16       | 40350         | Standoff                             |
| 17       | Ref Only      | 4-40 Nylon Lock Nut                  |
| 18       | Ref Only      | 8-32 x 3/8" Socket Head Cap Screw    |
| 19       | Ref Only      | 10-32 x 5/8" Pan Head Slot Screw     |
| 20       | 40060         | Grommet                              |
| 21       | Ref Only      | 4-40 x 3/8" Pan Head Slot Screw      |
| 22       | Ref Only      | 4-40 Hex Nut                         |
| 23       | 40034         | Main PCB                             |
| 24       | 40180         | Interface PCB                        |

**\* Will directly replace the original parts used in the Classic Panel Assembly.**

## 40504 Parts List (Additional items)

| Item No.     | Part Number   | Description                       |
|--------------|---------------|-----------------------------------|
| Not Pictured | 40275         | 24VDC Converter                   |
| Not Pictured | 40276 (6-Pin) | Power Connector w/ Wiring Harness |

## RS4000 Panel Mount Kit---Part # 40501

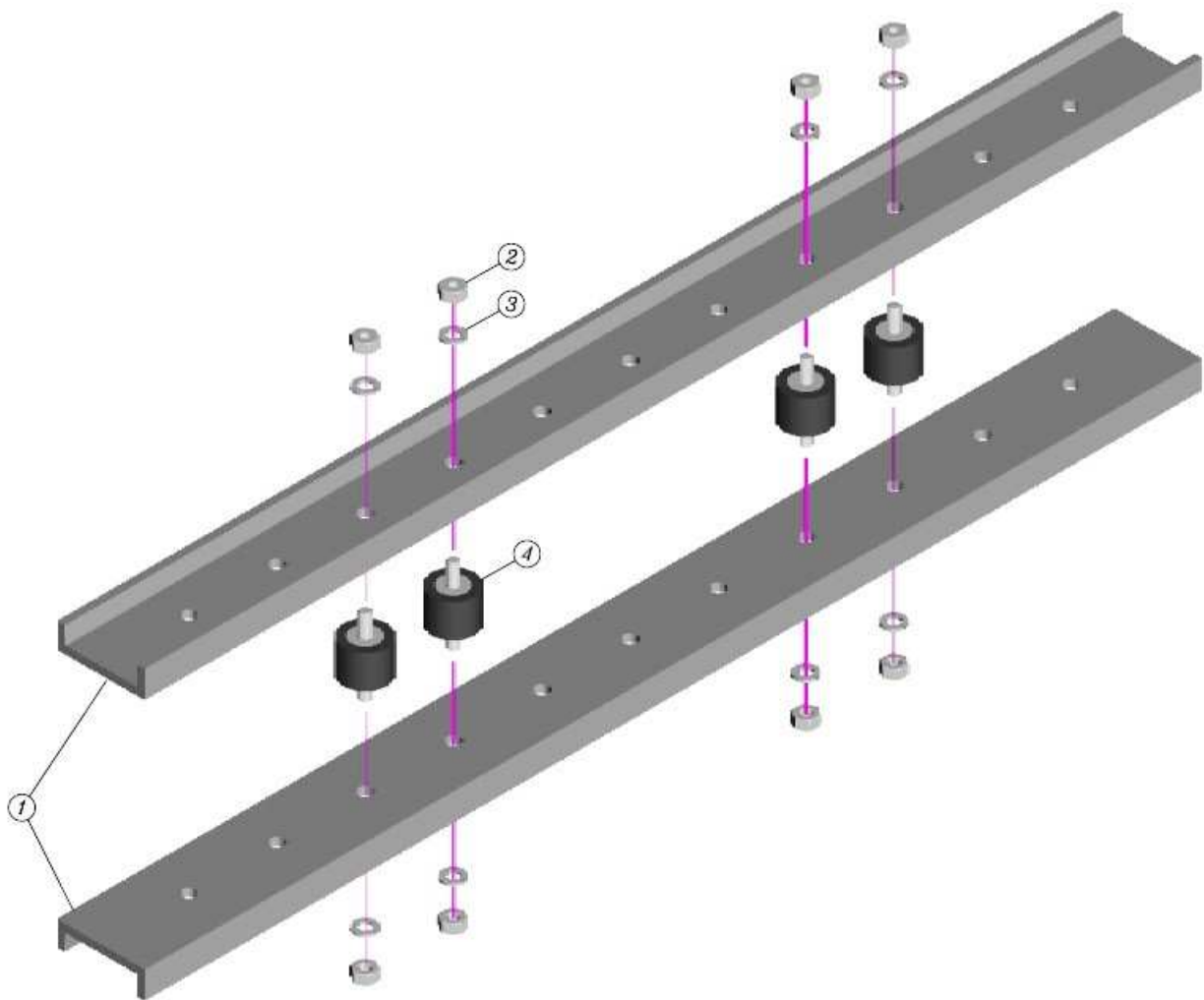



## 40501 Parts List

| <u>Item No.</u> | <u>Part Number</u> | <u>Description</u>     |
|-----------------|--------------------|------------------------|
| 1               | 40071              | Mounting Brackets      |
| 2               | Ref Only           | 1/4-20 Nylon Lock Nut  |
| 3               | Ref Only           | 1/4" Split Lock Washer |
| 4               | 40280              | Threaded Shock Mount   |

## RS4000 Lightbar Kit---Part # 40601

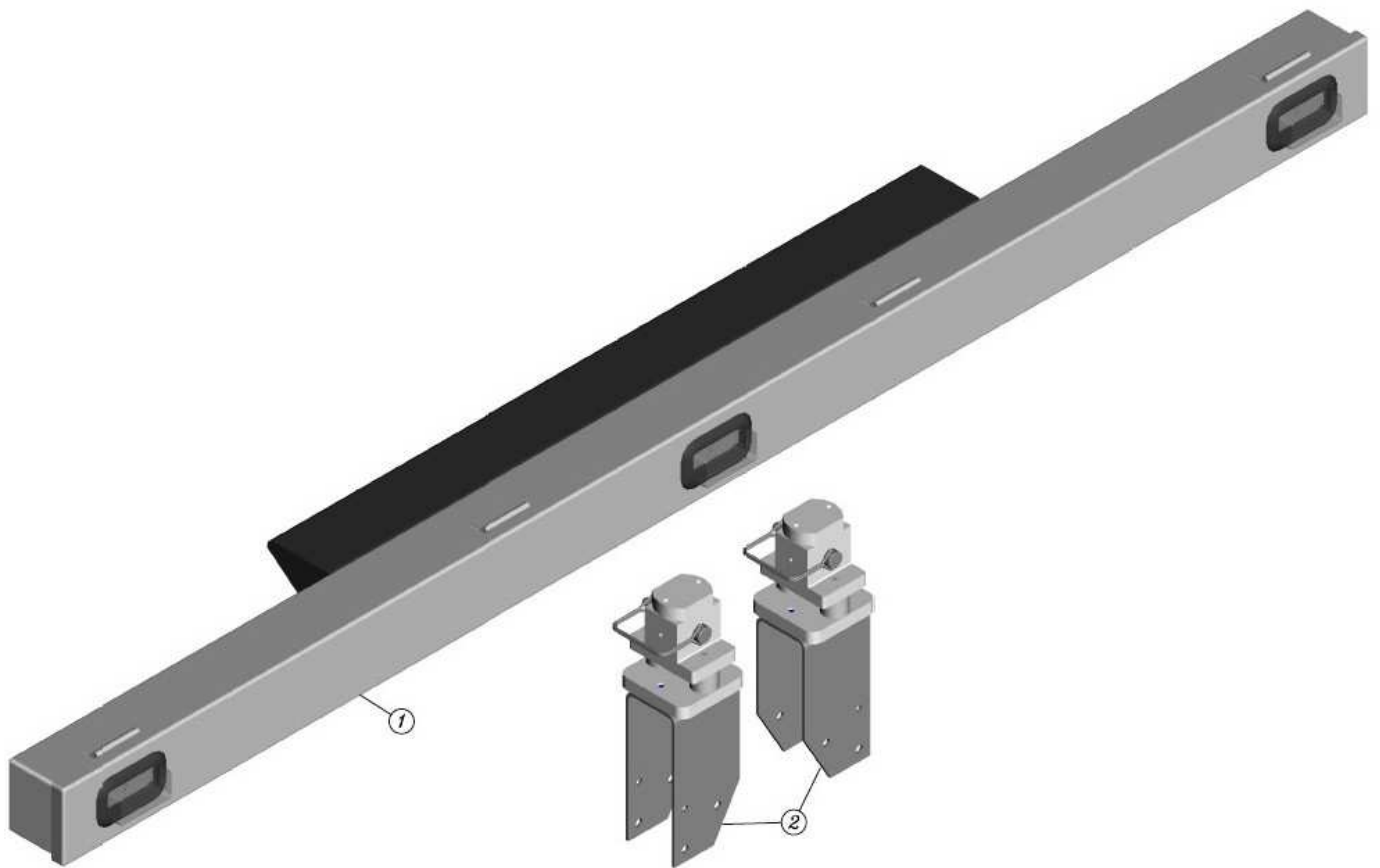

## 40601 Parts List

| <u>Item No.</u> | <u>Part Number</u> | <u>Description</u>           |
|-----------------|--------------------|------------------------------|
| 1               | 40510              | RS4000 LED Lightbar Assembly |
| 2               | 40511              | Lightbar Mounting Kit        |

## RS4000 LED Lightbar---Part # 40510

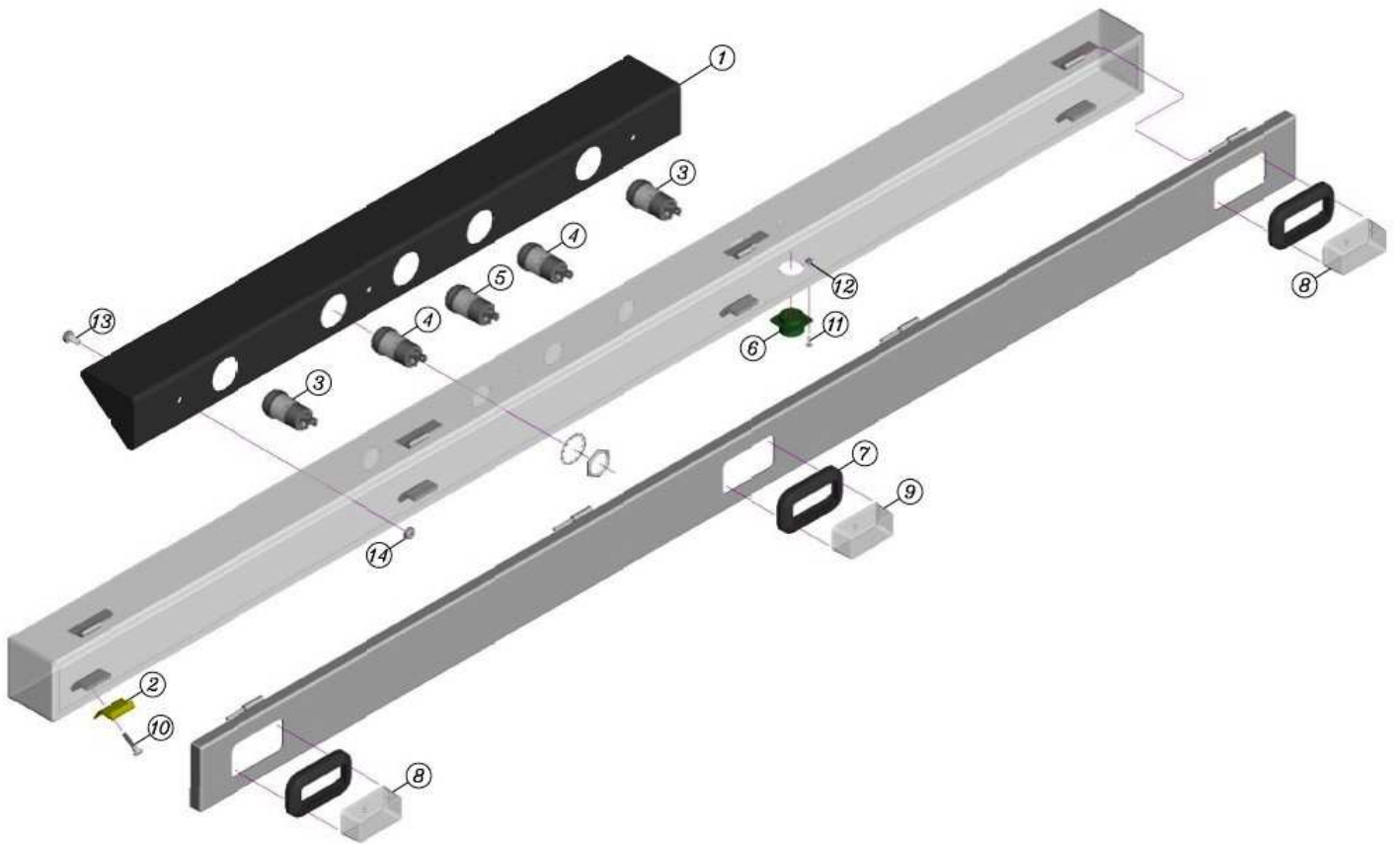

## 40510 Parts List

| Item No. | Part Number | Description                      |
|----------|-------------|----------------------------------|
| 1        | 743810      | Sun Shield                       |
| 2        | 40278       | Latch                            |
| 3        | 40011       | Red LED Limit Indicator          |
| 4        | 40012       | Yellow LED L/R Indicator         |
| 5        | 40010       | White LED Center Indicator       |
| 6        | 40023       | Connector w/ Wiring Harness      |
| 7        | 40013       | Light Indicator Grommet          |
| 8        | 40014       | Yellow HO LED L/R Indicator      |
| 9        | 40015       | White HO LED Center Indicator    |
| 10       | Ref Only    | 10-32 x 3/4" Pan Head Slot Screw |
| 11       | Ref Only    | 4-40 x 3/8" Pan Head Slot Screw  |
| 12       | Ref Only    | 4-40 Hex Nut                     |
| 13       | Ref Only    | 1/4-20 x 1/2" Hex Head Bolt      |
| 14       | Ref Only    | 1/4-20 Nylon Lock Nut            |

## RS4000 Lightbar Mounting Kit---Part # 40511

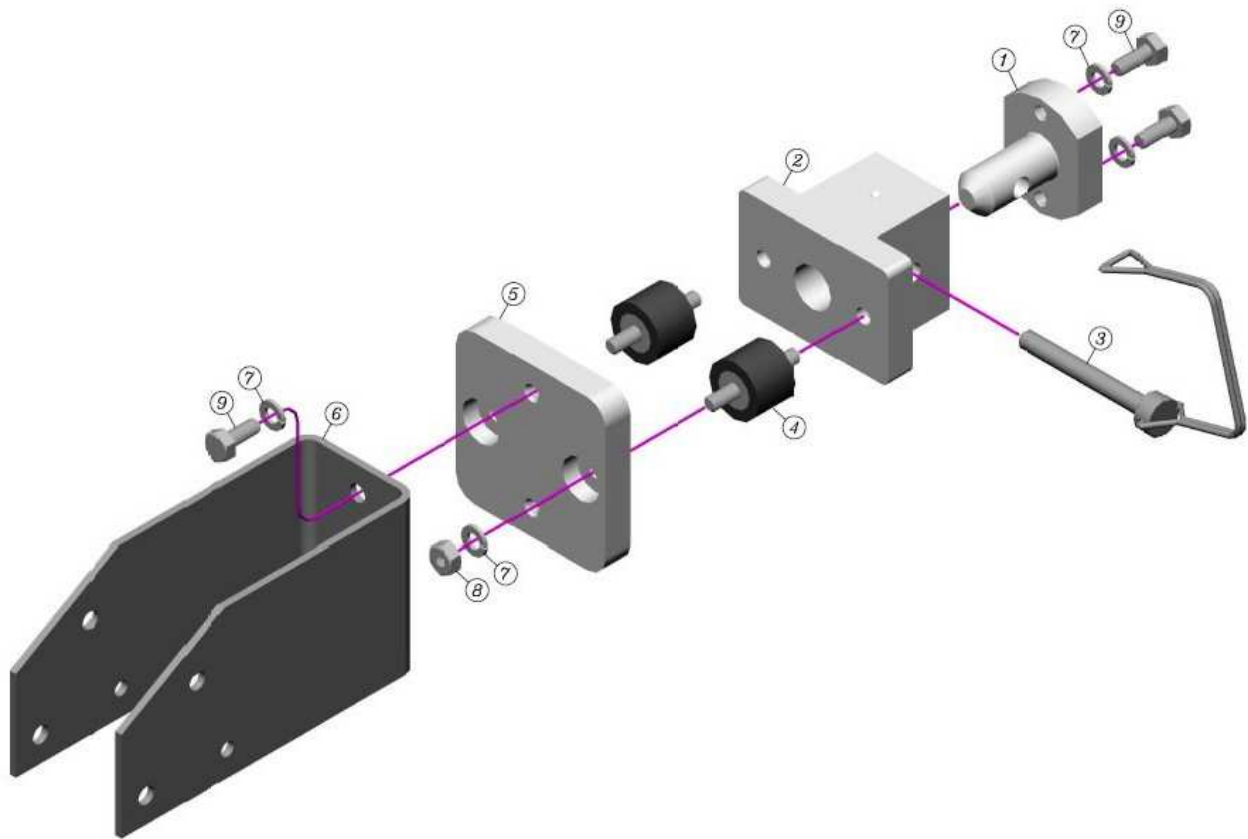

## 40511 Parts List

| <u>Item No.</u> | <u>Part Number</u> | <u>Description</u>      |
|-----------------|--------------------|-------------------------|
| 1               | 743809             | Mount Pin               |
| 2               | 729887             | 'T' Bracket             |
| 3               | 40024              | Hitch Pin               |
| 4               | 728128             | Threaded Shock Mounts   |
| 5               | 729891             | Adaptor Plate           |
| 6               | 729888             | 'U' Bracket             |
| 7               | Ref Only           | ¼" Slit Lock Washer     |
| 8               | Ref Only           | ¼-20 Nylon Lock Nut     |
| 9               | Ref Only           | ¼-20 x ½" Hex Head Bolt |

## RS4000 Sensor Kit---Part # 40602

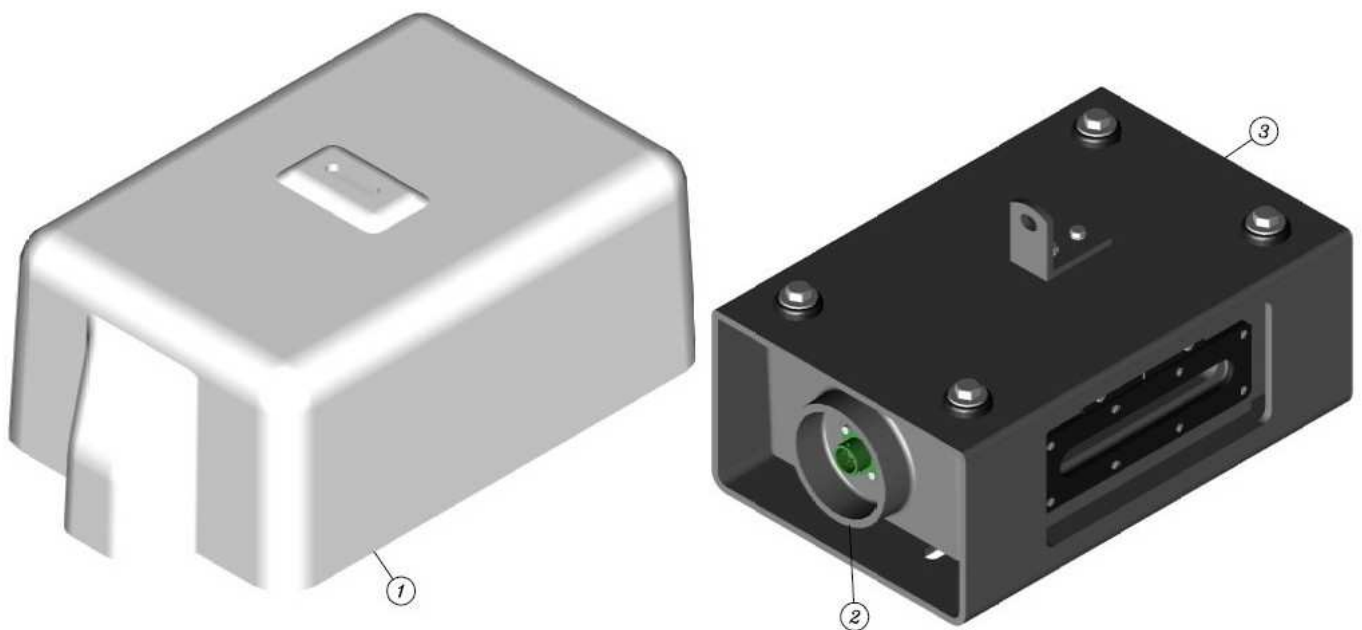



## 40602 Parts List

| <u>Item No.</u> | <u>Part Number</u> | <u>Description</u>     |
|-----------------|--------------------|------------------------|
| 1               | 40523              | Vandal Cover           |
| 2               | 40520              | RS4000 Sensor Assembly |
| 3               | 40522              | Sensor Mount Assembly  |
| Not Pictured    | 40521              | Laser Simulator        |

## RS4000 Sensor Mounting Kit---Part # 40522

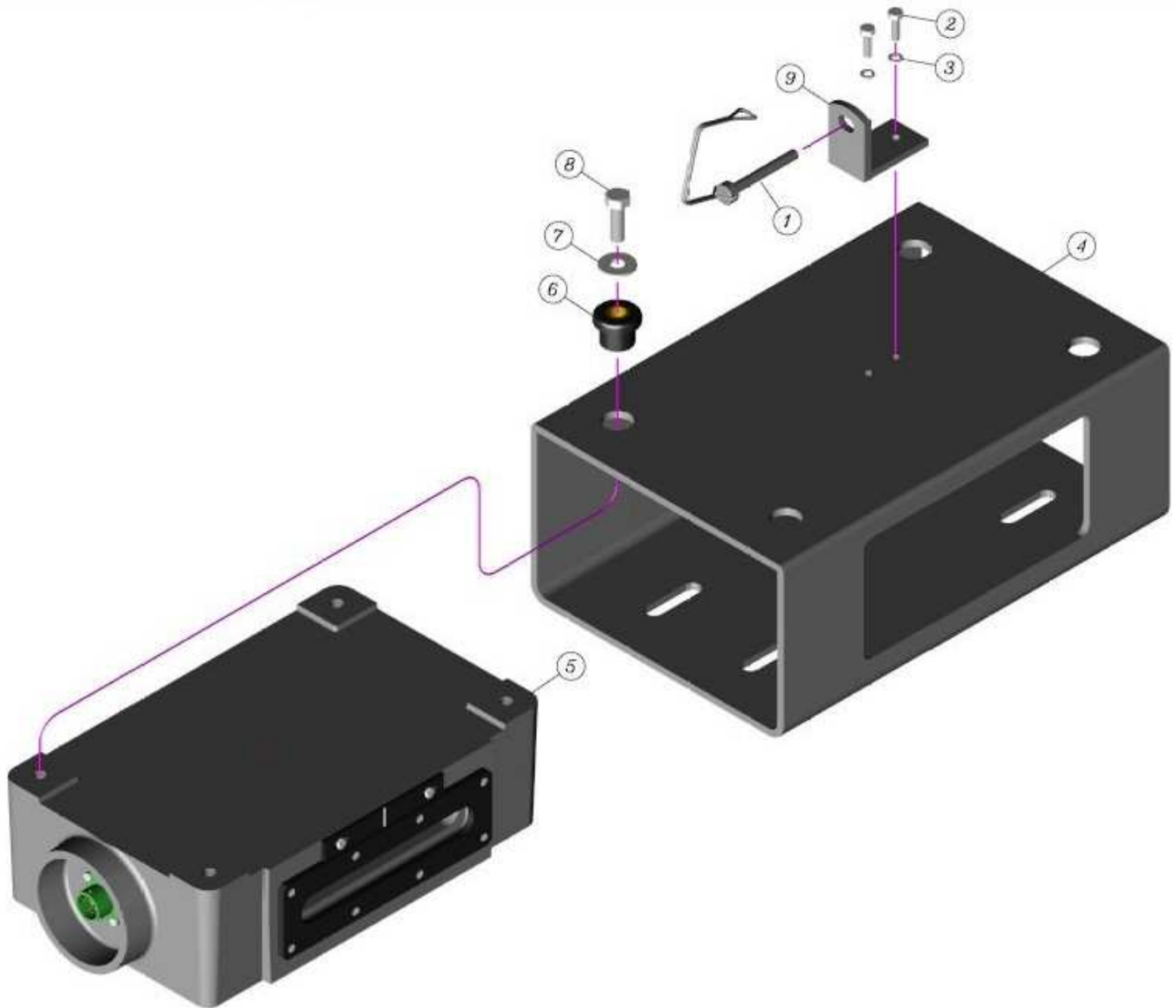

## 40522 Parts List

| <u>Item No.</u> | <u>Part Number</u> | <u>Description</u>             |
|-----------------|--------------------|--------------------------------|
| 1               | 739903             | Hitch Pin                      |
| 2               | Ref Only           | 10-32 x 5/8" Hex Head Bolt     |
| 3               | Ref Only           | #10 Split Lock Washer          |
| 4               | 729873             | Mount Frame                    |
| 5               | 40520              | RS4000 Sensor Assembly         |
| 6               | 40066              | Mount Grommet                  |
| 7               | Ref Only           | 5/16" x 3/4" OD Flat Washer    |
| 8               | Ref Only           | 5/16-18 x 1 1/4" Hex Head Bolt |
| 9               | 741523             | Lock Stable                    |

## RS4000 Laser Kit---Part # 40603



## **40603 Parts List**

| <b>Item No.</b> | <b>Part Number</b> | <b>Description</b>     |
|-----------------|--------------------|------------------------|
| 1               | 40530              | Laser-Cannon w/ Scope* |
| 2               | 40531              | Key Box / Power Cable  |
| 3               | 40532              | Case w/ Inserts        |

**\* 40530 must be purchased with a 40532 case.**

## RS4000 Laser/Cannon---Part # 40530

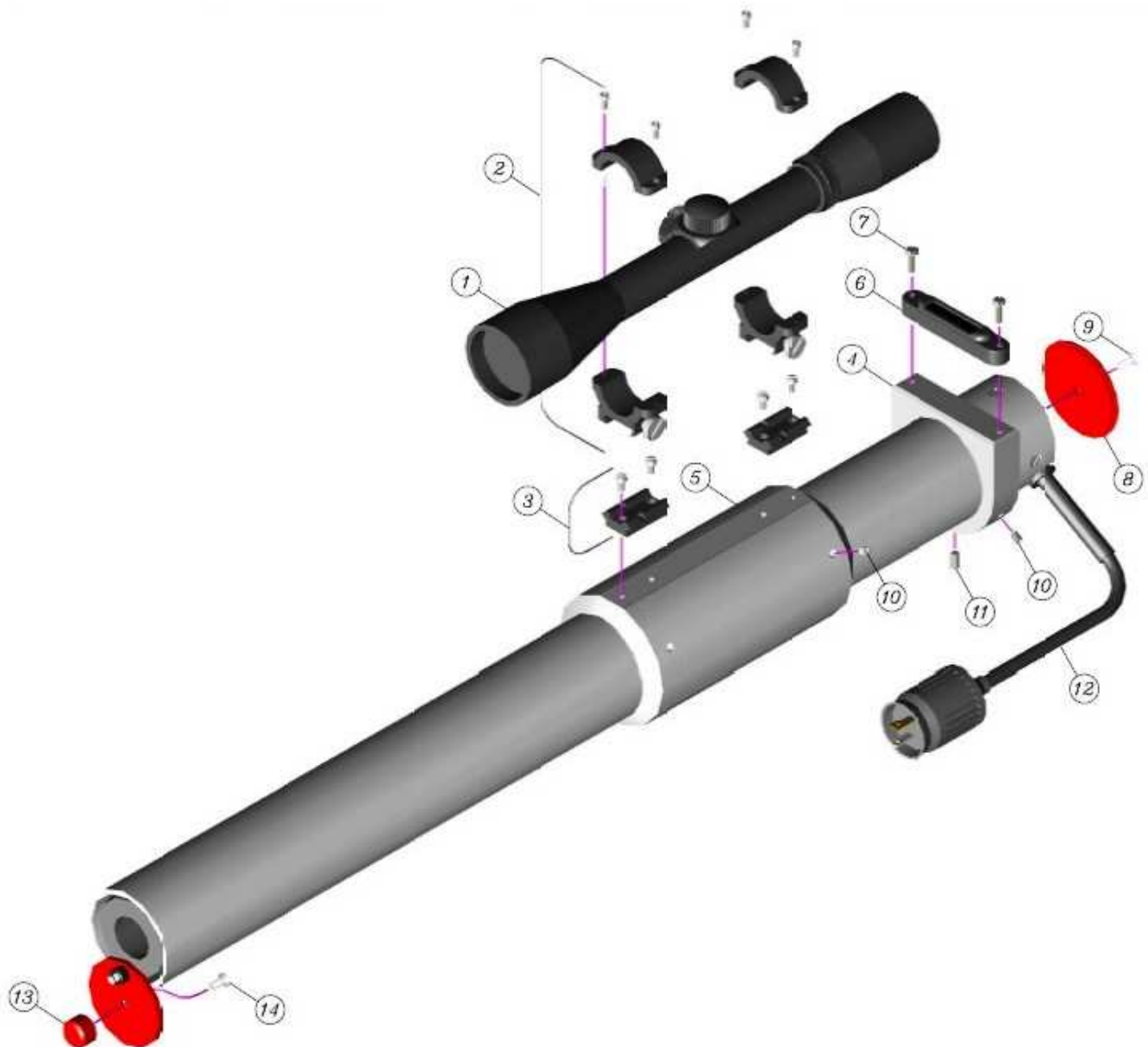

## 40530 Parts List

| Item No. | Part Number | Description                         |
|----------|-------------|-------------------------------------|
| 1        | 728124      | Scope Assembly                      |
| 2        | 728119      | Scope Mount (Set of 2)              |
| 3        | 728120      | Top Mount Base                      |
| 4        | 729880      | Vial Mount Ring                     |
| 5        | 40069       | Scope Mount Tube                    |
| 6        | 40261       | Vial Assembly                       |
| 7        | Ref Only    | 6-32 x 5/8" Pan Head Slot Screw     |
| 8        | 729741      | Rear Cover Plate                    |
| 9        | Ref Only    | 6-32 x 3/4" Flat Head Slot Screw    |
| 10       | Ref Only    | 10-24 x 3/16" Knurled Tip Set Screw |
| 11       | Ref Only    | 10-24 x 1/2" Knurled Tip Set Screw  |
| 12       | 743672      | Power Cable Assembly                |
| 13       | 742905      | Attenuator Knob                     |
| 14       | Ref Only    | 8-32 x 3/8" Flat Head Slot Screw    |

## RS4000 Laser Kit --- Part # 40605

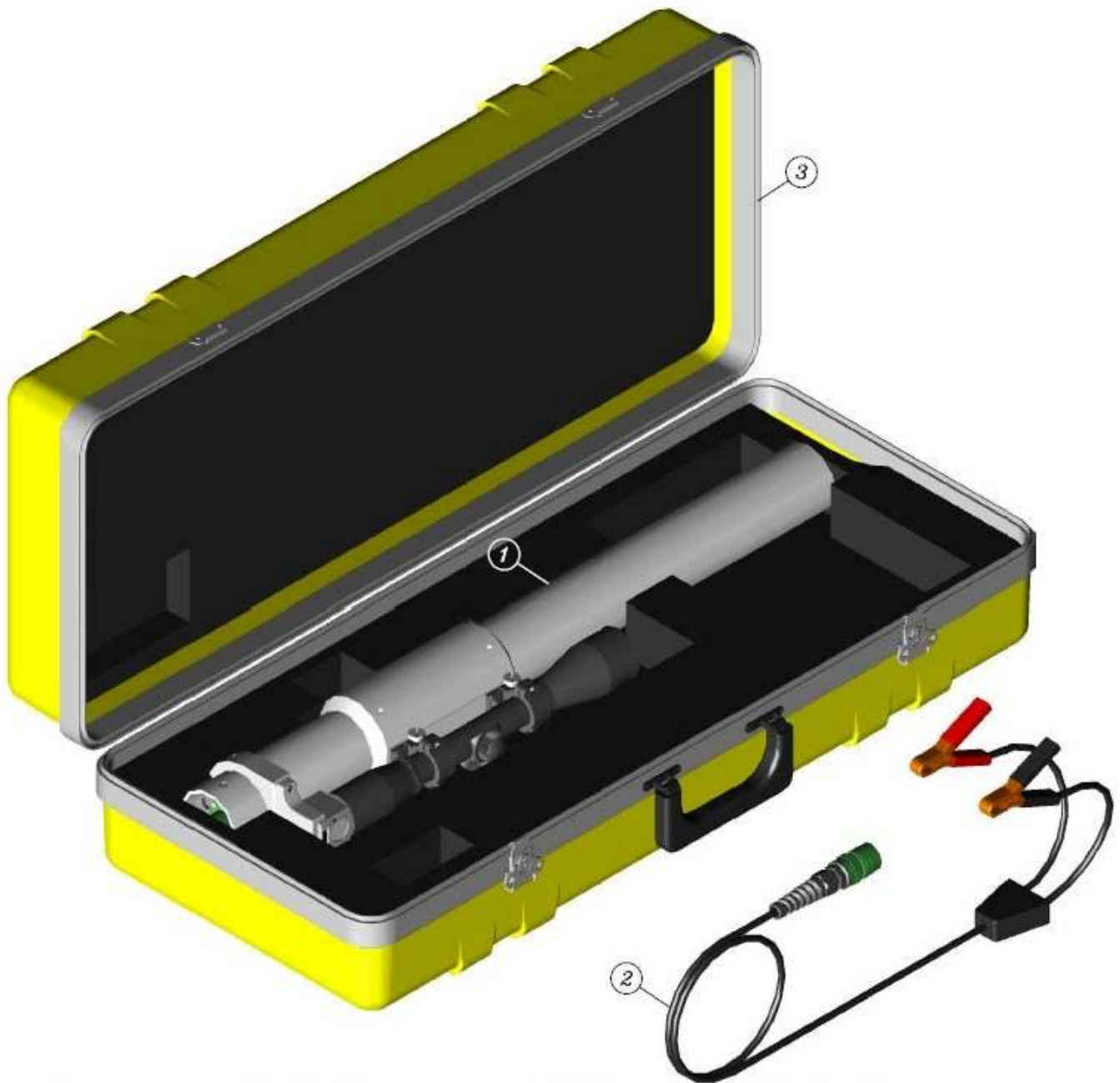



## **40605 Parts List**

| <b>Item No.</b> | <b>Part Number</b> | <b>Description</b>                  |
|-----------------|--------------------|-------------------------------------|
| 1               | 40533              | Laser-Cannon w/ Scope & Eye Bender* |
| 2               | 40534              | Key Box / Power Cable               |
| 3               | 40532              | Case w/ Inserts                     |

**\* 40533 must be purchased with a 40532 case.**

## RS4000 Laser/Cannon --- Part # 40533

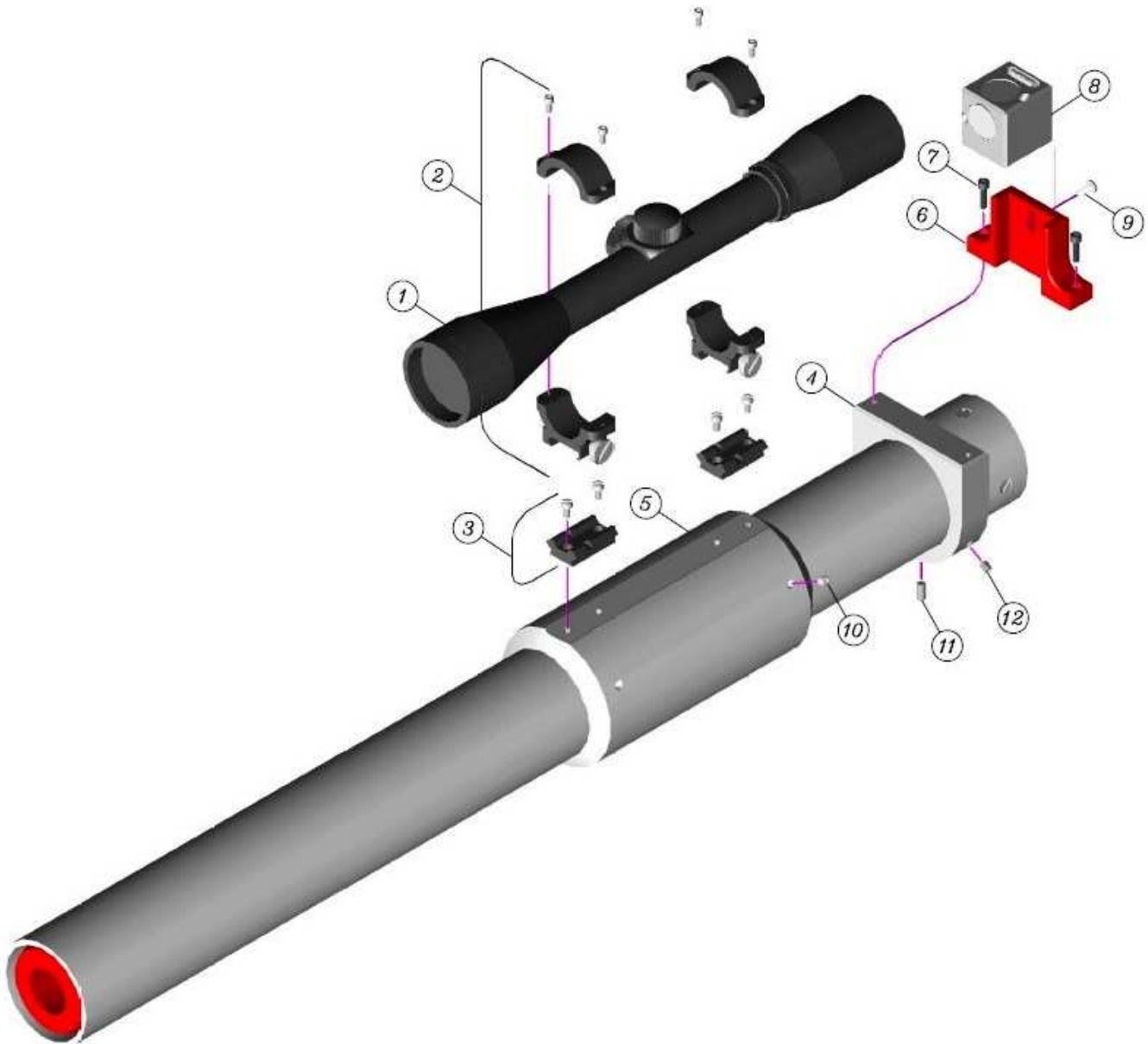

## 40533 Parts List

| <u>Item No.</u> | <u>Part Number</u> | <u>Description</u>                  |
|-----------------|--------------------|-------------------------------------|
| 1               | 728124             | Scope Assembly                      |
| 2               | 728119             | Scope Mount (Set of 2)              |
| 3               | 728120             | Top Mount Base                      |
| 4               | 729880             | Mount Ring                          |
| 5               | 40069              | Scope Mount Tube                    |
| 6               | 40337              | Eye Bender Mount                    |
| 7               | Ref Only           | 6-32 x 1/2" Button Head Screw       |
| 8               | 40341              | Eye Bender Assembly                 |
| 9               | Ref Only           | 6-32 x 1/2" Socket Cap Screw        |
| 10              | Ref Only           | 10-24 x 3/16" Knurled Tip Set Screw |
| 11              | Ref Only           | 10-24 x 1/2" Knurled Tip Set Screw  |
| 12              | Ref Only           | 10-24 x 3/16" Knurled Tip Set Screw |

# **RS4000 Tripod/Laser Mount---Part # 40535**

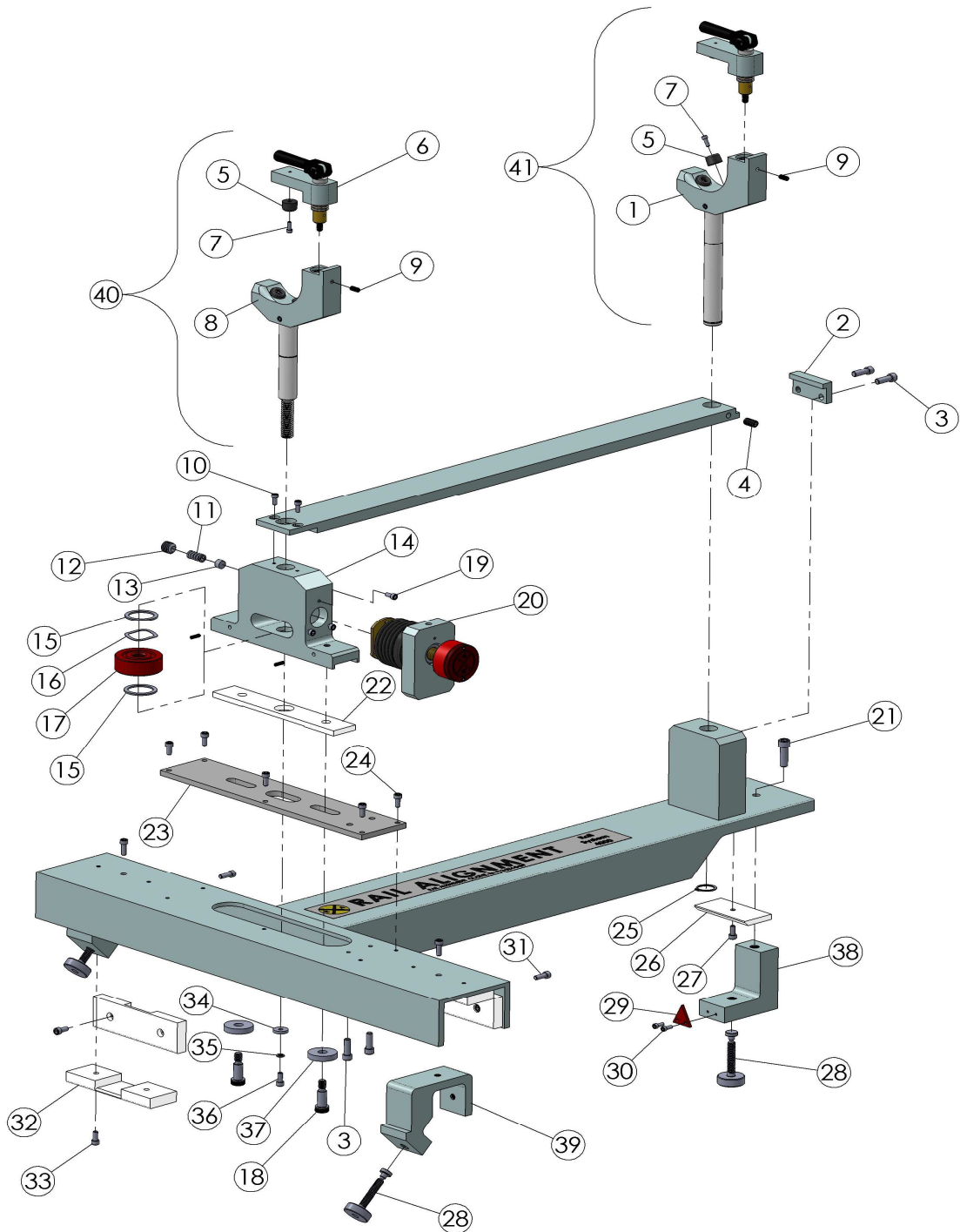

## 40535 Parts List

| Item No. | Part Number | Description                            |
|----------|-------------|--|
| 1        | 40105       | Front Support**                        |
| 2        | 40108       | Catch Block*                           |
| 3        | Ref Only    | 1/4-20 x 3/4" Socket Head Cap Screw    |
| 4        | Ref Only    | 5/16-18 x 5/8" Soc Cup Point Set Screw |
| 5        | 40144       | Bumper*                                |
| 6        | 40181       | Clamp Assembly**                       |
| 7        | Ref Only    | 6-32 x 5/16" Socket Head Cap Screw     |
| 8        | 40106       | Rear Support**                         |
| 9        | Ref Only    | 10-32 x 1/2" Cone Point Set Screw      |
| 10       | Ref Only    | 8-32 x 3/8" Socket Head Cap Screw      |
| 11       | 40141       | Spring*                                |
| 12       | Ref Only    | 1/2-13 x 1/2" Socket Head Set Screw    |
| 13       | 40125       | Plug*                                  |
| 14       | 40098       | Rear Support Block*                    |
| 15       | 40134       | Teflon Washer*                         |
| 16       | 40135       | Wave Washer*                           |
| 17       | 40133       | Knob w/ Lock Insert*                   |
| 18       | Ref Only    | 3/8"-5/16-18 x 3/4" S.H. Shoulder Bolt |
| 19       | Ref Only    | 8-32 x 3/8" Socket Head Cap Screw      |
| 20       | 40259       | Line Adjustment Assembly*              |
| 21       | Ref Only    | 5/16-18 x 1" Socket Head Cap Screw     |
| 22       | 40096       | Spacer/Wear Plate*                     |
| 23       | 40092       | Wear Plate                             |
| 24       | Ref Only    | 10-32 x 1/2" Socket Head Cap Screw     |
| 25       | 40132       | Snap Ring                              |
| 26       | 40097       | Spacer/Wear Plate                      |
| 27       | Ref Only    | 10-32 x 1/4" Socket Head Cap Screw     |
| 28       | 40145       | Knob Assembly w/ Swivel Pad            |
| 29       | 40095       | Pointer                                |
| 30       | Ref Only    | 6-32 x 3/8" Socket Head Cap Screw      |
| 31       | Ref Only    | 10-32 x 9/16" Socket Head Cap Screw    |
| 32       | 40099       | Spacer/Wear Plate                      |
| 33       | Ref Only    | 10-32 x 1/2" Socket Head Cap Screw     |
| 34       | 40127       | Spacer/Washer                          |
| 35       | Ref Only    | # 10 Split Lock Washer                 |
| 36       | Ref Only    | 10-32 x 1/2" Socket Head Cap Screw     |
| 37       | 40128       | Spacer/Washer                          |
| 38       | 40158       | Front Clamp Frame w/ Insert            |
| 39       | 40159       | Rear Clamp Frame w/ Inserts            |
| 40       | 40327       | Rear Support Assembly Complete         |
| 41       | 40326       | Front Support Assembly Complete        |

\* Will directly replace the original parts used in the Classic Tripod Assembly.

\*\*40105 & 40106 must also include 40181 to repair an Classic Tripod Assembly.

**RS4000 Cart/Buggy---Part # 40540, 40541, 40542,  
40543, 40544 & 40545**

- 40540---56.5" Buggy
- 40541---42" Buggy
- 40542---63" Buggy
- 40543---66" Buggy
- 40544---39" Buggy
- 40545---69.5" Buggy

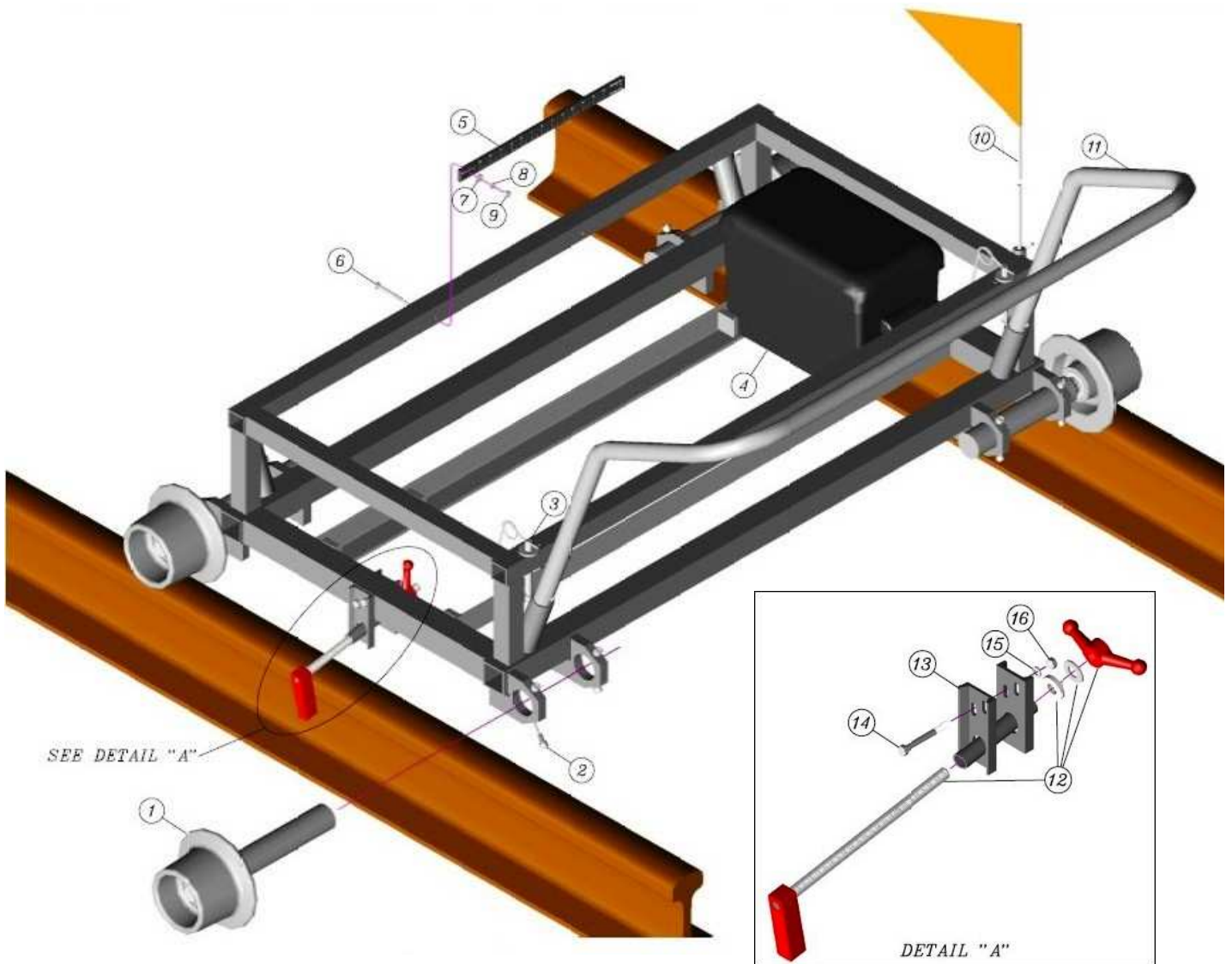

## 40540, 40541, 40542, 40543, 40544 & 40545

### Parts List

| Item No. | Part Number | Description                         |
|----------|-------------|-------------------------------------|
| 1        | 40148       | Wheel/Axel Assembly Complete        |
| 2        | Ref Only    | 3/8-16 x 5/8" Socket Head Cap Screw |
| 3        | 40279       | Storage Pin                         |
| 4        | 40074       | Battery Box                         |
| 5        | 40370       | Universal Metric/Standard Scale     |
| 6        | Ref Only    | 1/4-20 x 2 1/4" Hex Head Bolt       |
| 7        | Ref Only    | 1/4" Flat Washer                    |
| 8        | Ref Only    | 1/4" Split Lock Washer              |
| 9        | Ref Only    | 1/4-20 Hex Nut                      |
| 10       | 40081       | Whip Flag                           |
| 11       | 40274       | Handle                              |
| 12       | 40269       | Bias Clamp Assembly Complete        |
| 13       | 40273       | Bias Clamp Bracket                  |
| 14       | Ref Only    | 5/16-18 x 3" Hex Head Bolt          |
| 15       | Ref Only    | 5/16" Split Lock Washer             |
| 16       | Ref Only    | 5/16-18 Hex Nut                     |

# RS4000 56.5" Solar Cart/Buggy---Part # 40546

(Pg 1 of 2)

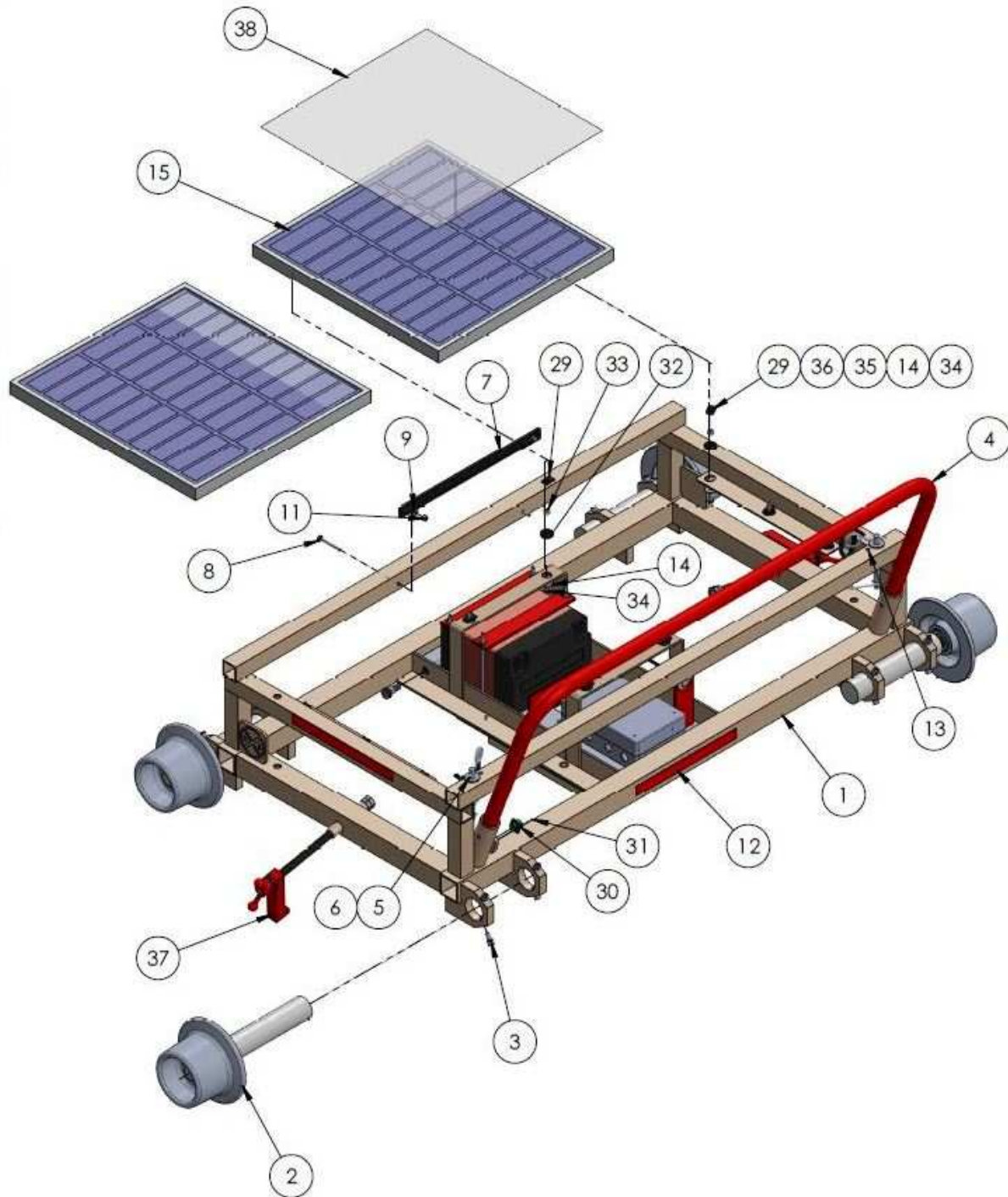



# RS4000 56.5" Solar Cart/Buggy---Part # 40546

(Pg 2 of 2)

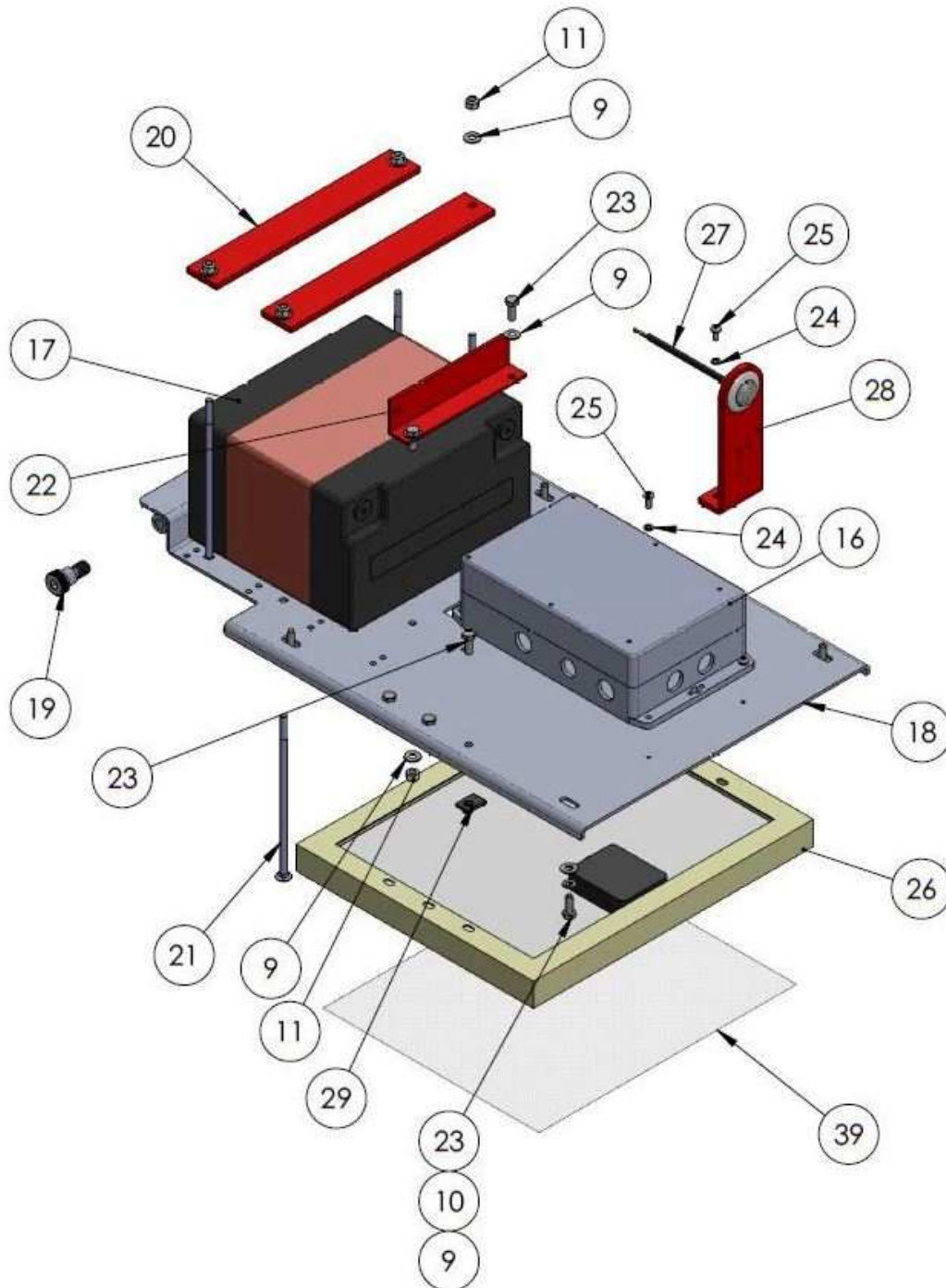

## 40546 Parts List

| Item No. | Part Number   | Description                         |
|----------|---------------|-------------------------------------|
| 1        | Not Available | 56.5" Solar Buggy Frame             |
| 2        | 40148         | Wheel/Axel Assembly Complete        |
| 3        | Ref Only      | 3/8"-16 x 5/8" Socket Head Screw    |
| 4        | 40356         | Solar Buggy Handle (Short)          |
| 5        | 40384         | Storage Lock                        |
| 5 Alt    | 40279         | Storage Pin (Non-Locking)           |
| 6        | Ref Only      | Chain                               |
| 7        | 40370         | Universal Metric/Standard Scale     |
| 8        | Ref Only      | 1/4"-20 x 2 1/4" Hex Head Bolt      |
| 9        | Ref Only      | 1/4" Flat Washer                    |
| 10       | Ref Only      | 1/4" Split Lock Washer              |
| 11       | Ref Only      | 1/4"-20 Hex Nut                     |
| 12       | 40291         | Reflective Decal                    |
| 13       | Ref Only      | Rivet                               |
| 14       | Ref Only      | 1/4" Fender Washer                  |
| 15       | 40361         | Large Solar Panel                   |
| 16       | 40359         | Charge Control Housing              |
| 17       | 40357         | 12V 55AH AGM Battery                |
| 18       | 40352         | Electronics Mounting Panel          |
| 19       | Ref Only      | 5/8-1/2-13x3/4 Shoulder Bolt        |
| 20       | 40353         | Battery Holddown                    |
| 21       | Ref Only      | 1/4"-20 x 7" Carriage Bolt          |
| 22       | 40355         | Battery Retainer                    |
| 23       | Ref Only      | 1/4"-20 x 3/4" Hex Head Bolt        |
| 24       | Ref Only      | #10 Lock Washer                     |
| 25       | Ref Only      | 10-32 x 1/2 Phillips Panhead        |
| 26       | 40362         | Small Solar Panel                   |
| 27       | 40366         | Safety Light                        |
| 28       | 40367         | Safety Light Mount                  |
| 29       | Ref Only      | U-Nut, 1/4"-20                      |
| 30       | 40385         | Connector Blank                     |
| 31       | Ref Only      | 4-40 x 3/8" Phillips Panhead        |
| 32       | 40376         | Grommet                             |
| 33       | 40377         | Standoff                            |
| 34       | Ref Only      | 1/4"-20 x 1 1/4" Hex Head Bolt      |
| 35       | 40389         | Grommet                             |
| 36       | 40390         | Standoff                            |
| 37       | 40388         | Clamp Assembly                      |
| 38       | 40382         | Solar Panel Screen Protector, Large |
| 39       | 40383         | Solar Panel Screen Protector, Small |

# RS4000 Plasser Servo---Part # 40550 & 40553

(Pg 1 of 3)

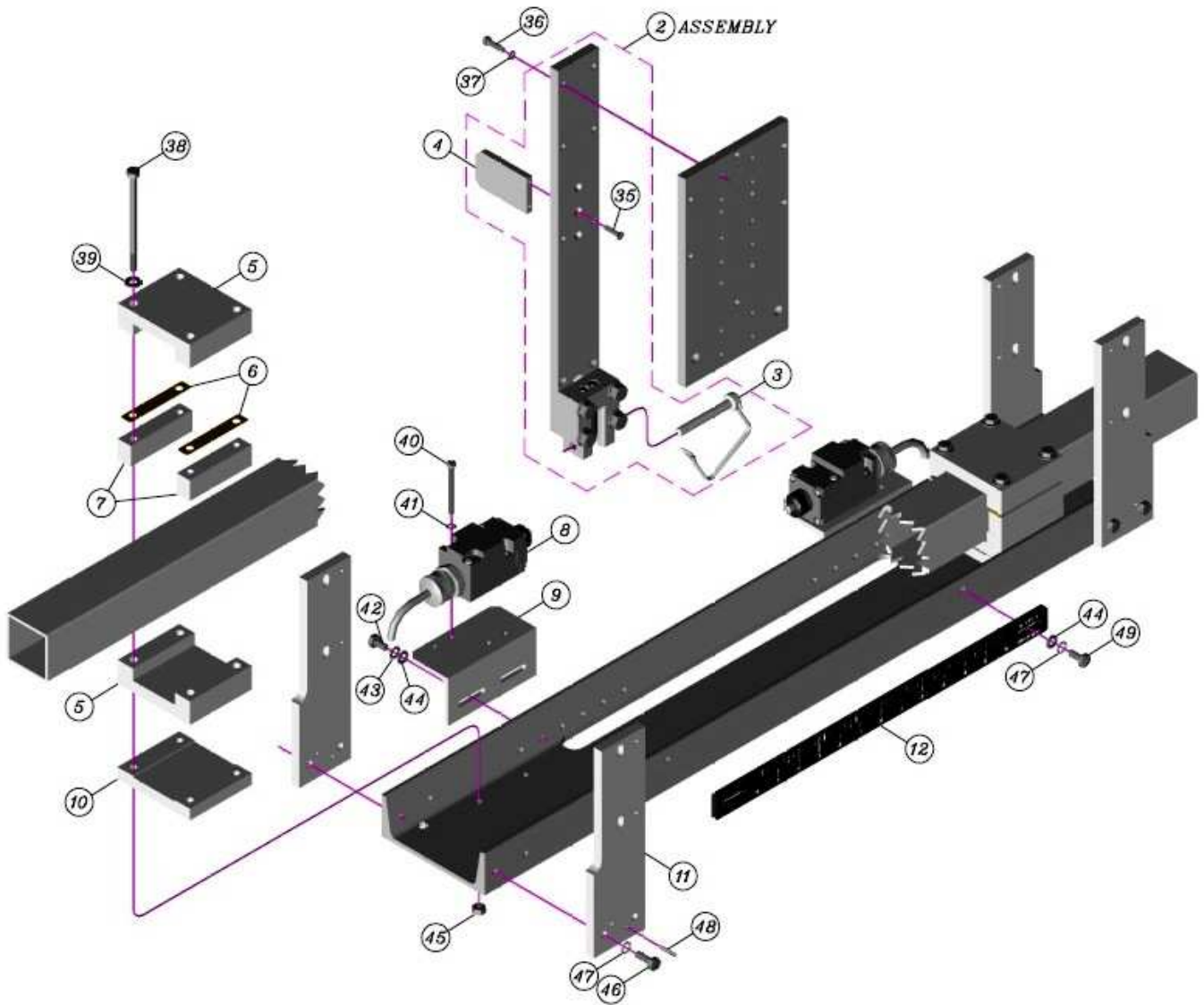

# RS4000 Plasser Servo---Part # 40550 & 40553

(Pg 2 of 3)

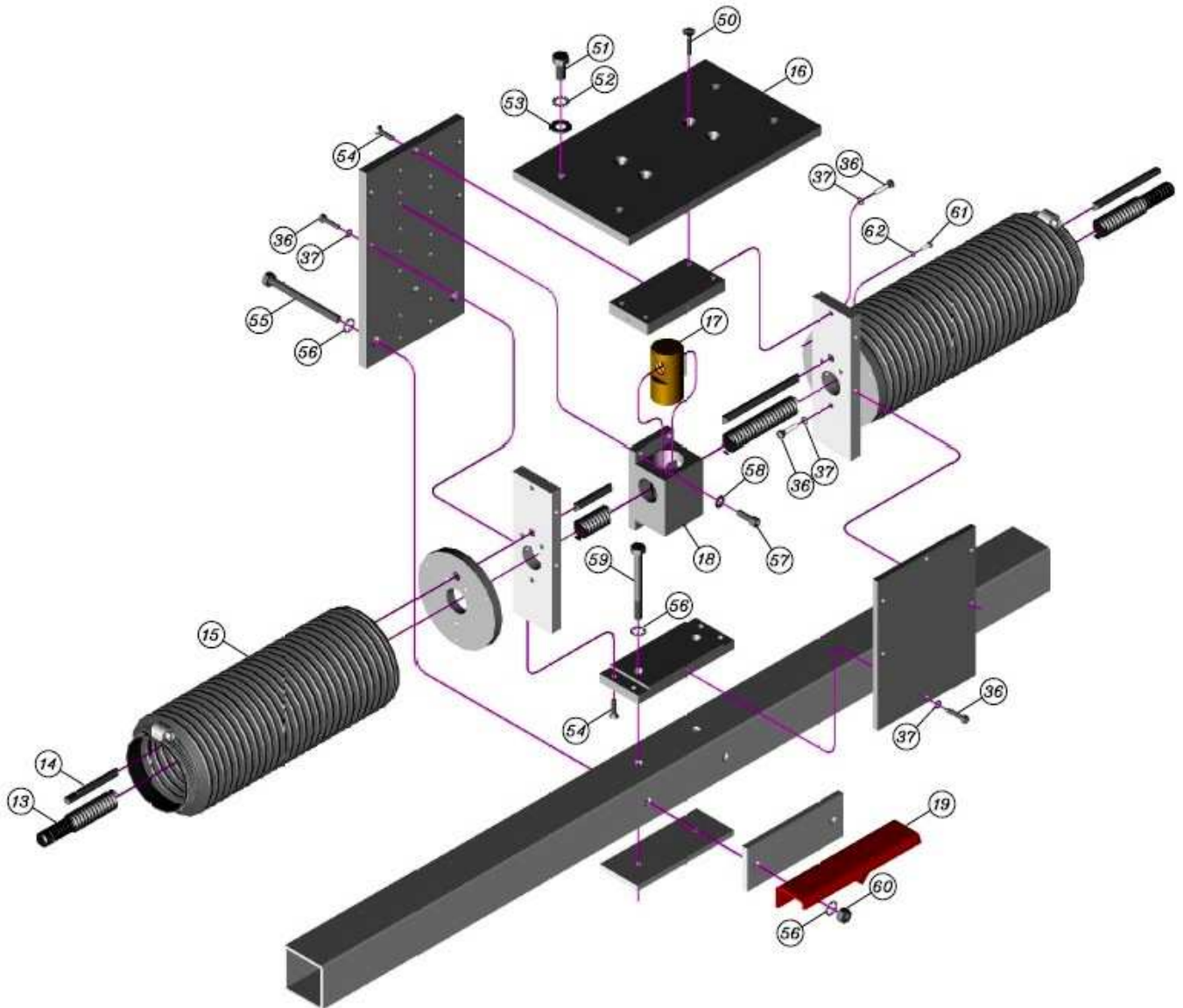

## RS4000 Plasser Servo---Part # 40550 & 40553

(Pg 3 of 3)

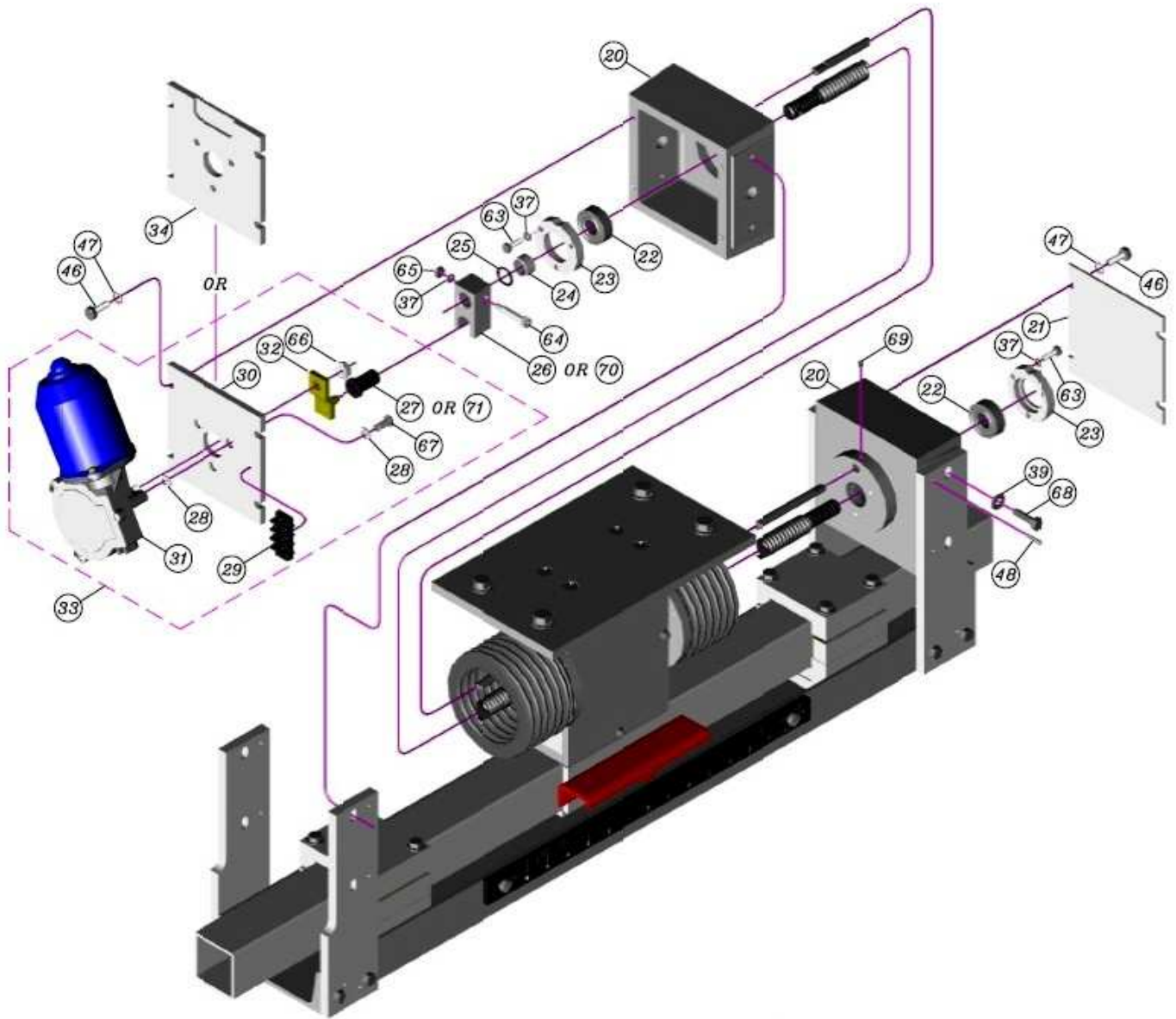

## 40550 & 40553 Parts List (Pg 1 of 2)

| Item No. | Part Number | Description                                  |
|----------|-------------|--|
| 1        | 40550       | Plasser Servo Assembly w/o Motor             |
| 1        | 40553       | Plasser Servo Assembly w/ RA Motor           |
| 2        | 40262       | Wire Guide Assembly, Complete                |
| 3        | 739903      | Hitch Pin                                    |
| 4        | 40189       | Limit Switch Actuator                        |
| 5        | 40208       | Outer Bearing                                |
| 6        | 40212       | Shim   |
| 7        | 40204       | Bearing Spacer                               |
| 8        | 40072       | Limit Switch                                 |
| 9        | 40200       | Limit Switch Mounting Bracket                |
| 10       | 40206       | Bearing Block                                |
| 11       | 40186       | Drive Support Plate                          |
| 12       | 40370       | Universal Standard Metric Scale              |
| 13       | 40173       | Jack Screw*                                  |
| 14       | 40213       | Support Rod                                  |
| 15       | 40077       | Bellows/Flexible Shield w/ Clamps (SET)      |
| 16       | 40191       | Sensor Plate                                 |
| 17       | 40172       | Brass Nut*                                   |
| 18       | 40203       | Nut Guide                                    |
| 19       | 40199       | Pointer Bracket                              |
| 20       | 40043       | 5X5 Cast Housing                             |
| 21       | 40197       | Cover Plate                                  |
| 22       | 40078       | Jack Screw Bearing                           |
| 23       | 40209       | Bearing Retainer                             |
| 24       | 40205       | Bearing Spacer                               |
| 25       | 40271       | Non-Metallic Washer/Shim                     |
| 26       | 40227       | Crank Shaft (For use w/ RA Motor)**          |
| 27       | 40226       | Sleeve (For use w/ RA Motor)**               |
| 28       | 40225       | Non-Metallic Shoulder Washer                 |
| 29       | 40085       | Terminal Block                               |
| 30       | 40214       | Motor Mounting Plate (For use w/ RA Motor)** |
| 31       | 40075       | RA 24VDC Servo Motor**                       |
| 32       | 40076       | RA Motor Arm**                               |
| 33       | 40281       | RA Servo Motor Assembly w/ Sleeve            |
| 34       | 40198       | Motor Mount Plate (For use w/ Plsr Motor)    |
| 35       | Ref Only    | 8-32 x 3/4" Flat Head Screw                  |
| 36       | Ref Only    | 10-24 x 3/4" Pan Head Slot Screw             |
| 37       | Ref Only    | #10 Split Ring Lock Washer**                 |
| 38       | Ref Only    | 1/4-20 x 4" Hex Head Screw                   |
| 39       | Ref Only    | 1/4" Flat Washer                             |
| 40       | Ref Only    | 10-24 x 2" Pan Head Slot Screw               |

## 40550 & 40553 Parts List (Pg 2 of 2)

| Item No. | Part Number | Description                                    |
|----------|-------------|--|
| 41       | Ref Only    | #10 External Tooth Lock Washer                 |
| 42       | Ref Only    | 1/4-20 x 1/2" Hex Head Screw                   |
| 43       | Ref Only    | 1/4" External Tooth Lock Washer                |
| 44       | Ref Only    | 1/4" Flat Washer                               |
| 45       | Ref Only    | 1/4-20 Hex Nut                                 |
| 46       | Ref Only    | 1/4-20 x 3/4" Hex Head Screw                   |
| 47       | Ref Only    | 1/4" Internal Tooth Lock Washer                |
| 48       | Ref Only    | 1/8" x 3/4" Spring Pin                         |
| 49       | Ref Only    | 1/2-20 x 5/8" Pan Head Slot Screw              |
| 50       | Ref Only    | 1/4-20 x 1" Flat Head Screw                    |
| 51       | Ref Only    | 3/8-16 x 3/4" Hex Head Screw                   |
| 52       | Ref Only    | 3/8" External Tooth Lock Washer                |
| 53       | Ref Only    | 3/8" Flat Washer                               |
| 54       | Ref Only    | 10-24 x 3/4" Flat Head Screw                   |
| 55       | Ref Only    | 5/16-18 x 3 1/2" Hex Head Screw                |
| 56       | Ref Only    | 5/16" Internal Tooth Lock Washer               |
| 57       | Ref Only    | 1/4-20 x 3/4" Socket Head Screw                |
| 58       | Ref Only    | 1/4-20 Split Ring Lock Washer                  |
| 59       | Ref Only    | 5/16-18 x 3" Hex Head Screw                    |
| 60       | Ref Only    | 5/16-18 Hex Nut                                |
| 61       | Ref Only    | 6-32 x 3/8" Pan Head Slot Screw                |
| 62       | Ref Only    | #6 Split Ring Lock Washer                      |
| 63       | Ref Only    | 10-32 x 5/8" Hex Head Screw                    |
| 64       | Ref Only    | 10-24 Thd, 1" Long x 1/4" Dia. Shoulder Bolt** |
| 65       | Ref Only    | 10-24 Hex Nut**                                |
| 66       | Ref Only    | 8mm-1.25 Serrated Flange Nut**                 |
| 67       | Ref Only    | 1/4-20 x 5/8" Button Head Screw**              |
| 68       | Ref Only    | 1/4-20 x 1" Hex Head Screw                     |
| 69       | Ref Only    | 10-32 x 3/16" Cup Point Set Screw              |
| 70       | 40211       | Crank Shaft (For use w/ Plsr Motor)            |
| 71       | 40210       | Sleeve (For use w/ Plsr Motor)                 |

**\*Updated Part-These parts must be replaced as a set in Yellow assemblies.**

**\*\* For use with Rail Alignment standard servo motor and its parts only. This part will not work with the optional Plasser-Theurer motor or its parts.**

### **Available directly from Plasser:**

Plasser-Theurer Servo Motor --- Part # EL-T34.00P

Plasser-Theurer Servo Motor Arm --- Part # EL-T34.03-SHORT

# RS4000 Jackson Servo---Part # 40551 (Pg 1 of 3)

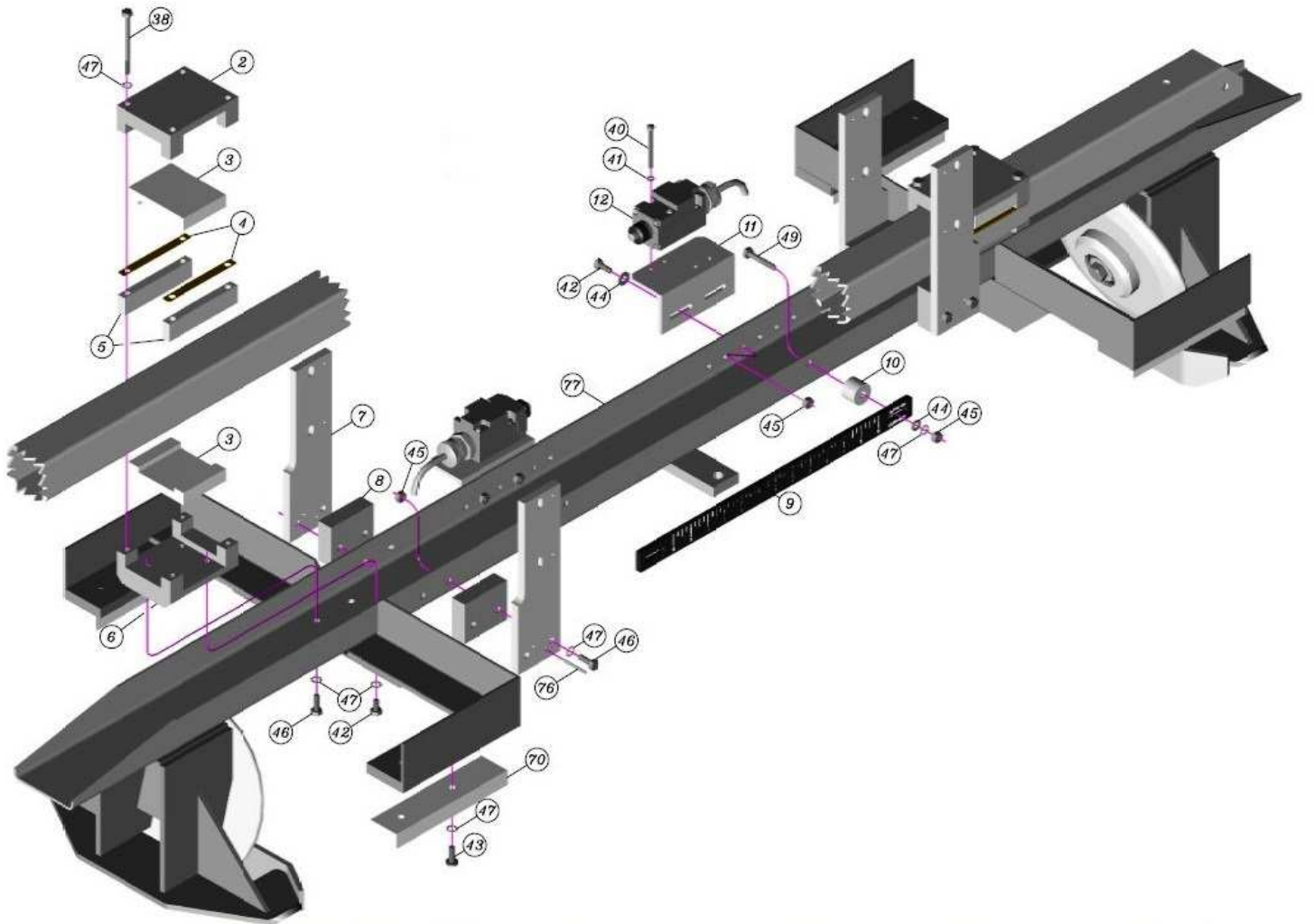



# RS4000 Jackson Servo---Part # 40551 (Pg 2 of 3)

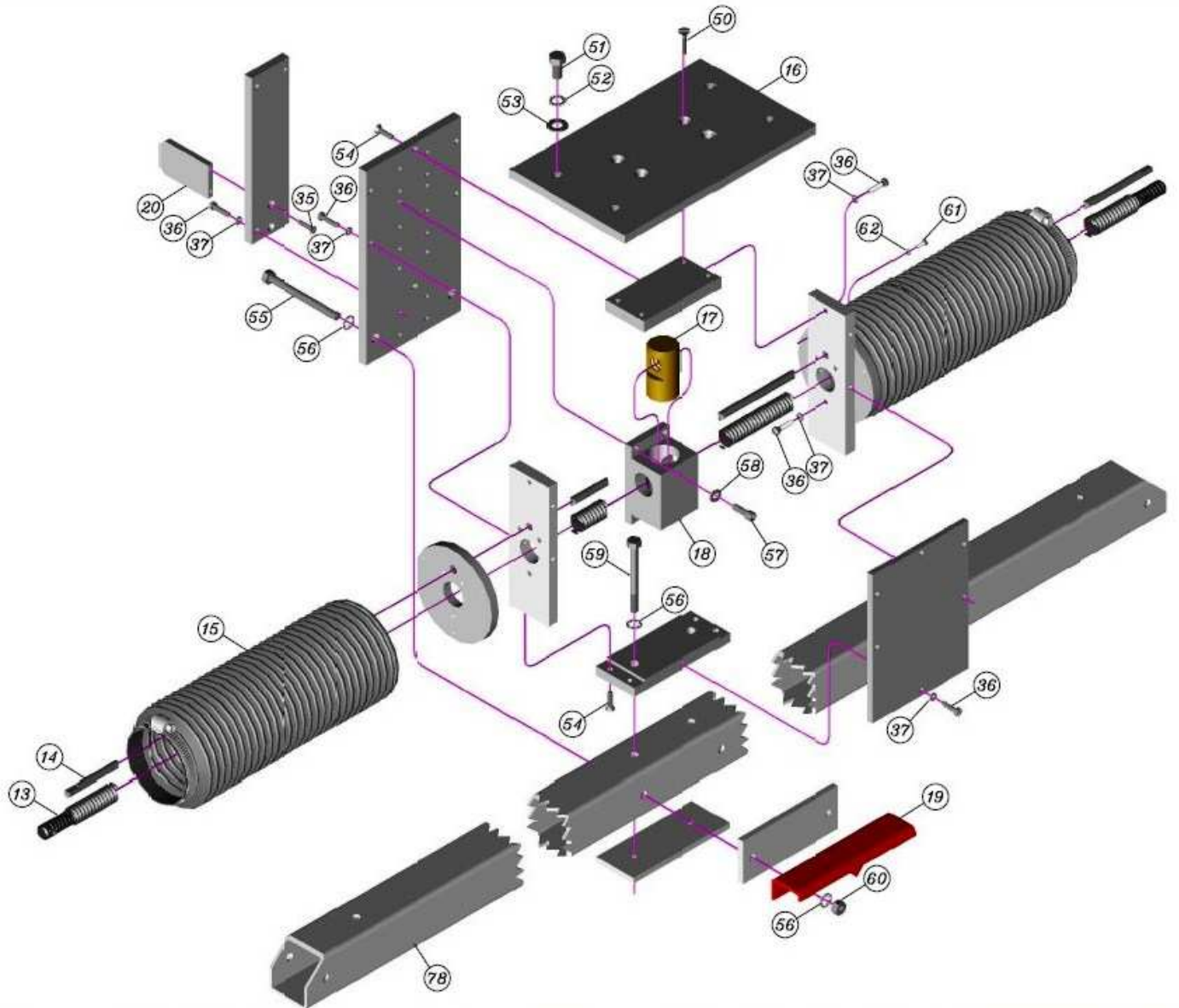

# RS4000 Jackson Servo---Part # 40551 (Pg 3 of 3)

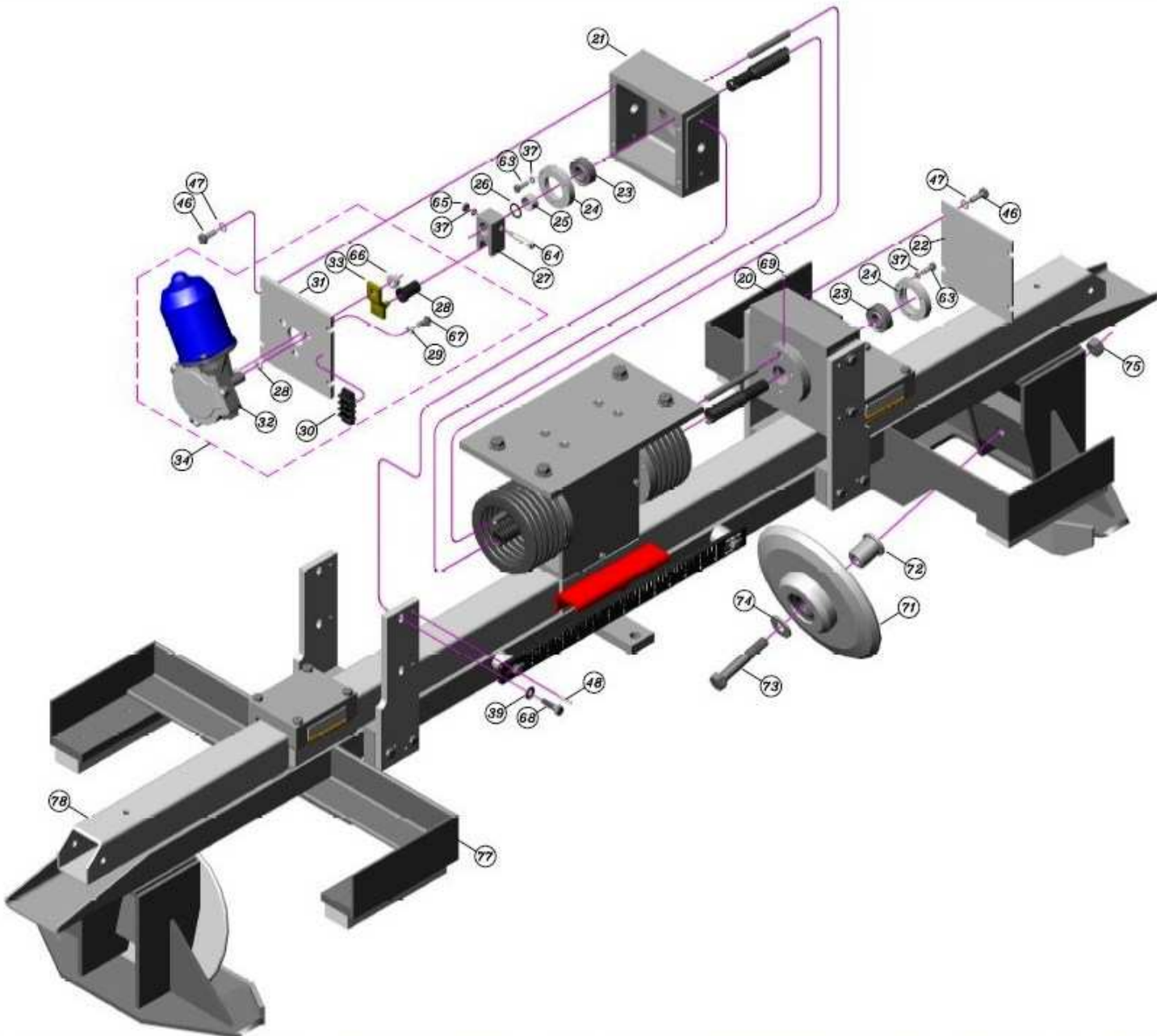

## 40551 Parts List (Pg 1 of 2)

| Item No. | Part Number | Description                             |
|----------|-------------|---|
| 1        | 40551       | Jackson Servo Assembly                  |
| 2        | 40215       | Bearing Block                           |
| 3        | 40230       | Bearing                                 |
| 4        | 40228       | Shim                                    |
| 5        | 40221       | Bearing Spacer                          |
| 6        | 40218       | Lower Bearing Block                     |
| 7        | 40186       | Drive Support Plate                     |
| 8        | 40217       | Support Plate Spacer                    |
| 9        | 40370       | Universal Standard/Metric Scale         |
| 10       | 40220       | Scale Spacer                            |
| 11       | 40200       | Limit Switch Mounting Bracket           |
| 12       | 40072       | Limit Switch                            |
| 13       | 40173       | Jack Screw*                             |
| 14       | 40213       | Support Rod                             |
| 15       | 40077       | Bellows/Flexible Shield w/ Clamps (SET) |
| 16       | 40191       | Sensor Plate                            |
| 17       | 40172       | Brass Nut*                              |
| 18       | 40203       | Nut Guide                               |
| 19       | 40199       | Pointer Bracket                         |
| 20       | 40189       | Limit Switch Actuator                   |
| 21       | 40043       | 5X5 Cast Housing                        |
| 22       | 40197       | Cover Plate                             |
| 23       | 40078       | Jack Screw Bearing                      |
| 24       | 40209       | Bearing Retainer                        |
| 25       | 40205       | Bearing Spacer                          |
| 26       | 40271       | Non-Metallic Washer/Shim                |
| 27       | 40227       | Crank Shaft                             |
| 28       | 40226       | Sleeve                                  |
| 29       | 40225       | Non-Metallic Shoulder Washer            |
| 30       | 40085       | Terminal Block                          |
| 31       | 40214       | Motor Mounting Plate                    |
| 32       | 40075       | 24VDC Servo Motor                       |
| 33       | 40076       | Motor Arm                               |
| 34       | 40281       | Servo Motor Assembly w/ Sleeve          |
| 35       | Ref Only    | 8-32 x 3/4" Flat Head Screw             |
| 36       | Ref Only    | 10-24 x 3/4" Pan Head Slot Screw        |
| 37       | Ref Only    | #10 Split Ring Lock Washer              |
| 38       | Ref Only    | 1/4-20 x 3" Hex Head Screw              |
| 39       | Ref Only    | 1/4" Flat Washer                        |
| 40       | Ref Only    | 10-24 x 2" Pan Head Slot Screw          |
| 41       | Ref Only    | #10 External Tooth Lock Washer          |

## 40551 Parts List (Pg 2 of 2)

| Item No. | Part Number | Description                                  |
|----------|-------------|--|
| 42       | Ref Only    | 1/4-20 x 1/2" Hex Head Screw                 |
| 43       | Ref Only    | 1/4-20 x 3/4" Pan Head Slot Screw            |
| 44       | Ref Only    | 1/4" Flat Washer                             |
| 45       | Ref Only    | 1/4-20 Hex Nut                               |
| 46       | Ref Only    | 1/4-20 x 3/4" Hex Head Screw                 |
| 47       | Ref Only    | 1/4" Internal Tooth Lock Washer              |
| 48       | Ref Only    | 1/8" x 3/4" Spring Pin                       |
| 49       | Ref Only    | 1/4-20 x 1 1/2" Hex Head Screw               |
| 50       | Ref Only    | 1/4-20 x 1" Flat Head Screw                  |
| 51       | Ref Only    | 3/8-16 x 3/4" Hex Head Screw                 |
| 52       | Ref Only    | 3/8" External Tooth Lock Washer              |
| 53       | Ref Only    | 3/8" Flat Washer                             |
| 54       | Ref Only    | 10-24 x 3/4" Flat Head Screw                 |
| 55       | Ref Only    | 5/16-18 x 3 1/2" Hex Head Screw              |
| 56       | Ref Only    | 5/16" Internal Tooth Lock Washer             |
| 57       | Ref Only    | 1/4-20 x 3/4" Socket Head Screw              |
| 58       | Ref Only    | 1/4" Split Ring Lock Washer                  |
| 59       | Ref Only    | 5/16-18 x 3" Hex Head Screw                  |
| 60       | Ref Only    | 5/16-18 Hex Nut                              |
| 61       | Ref Only    | 6-32 x 3/8" Pan Head Slot Screw              |
| 62       | Ref Only    | #6 Split Ring Lock Washer                    |
| 63       | Ref Only    | 10-32 x 5/8" Hex Head Screw                  |
| 64       | Ref Only    | 10-24 Thd, 1" Long x 1/4" Dia. Shoulder Bolt |
| 65       | Ref Only    | 10-24 Hex Nut                                |
| 66       | Ref Only    | 8mm-1.25 Serrated Flange Nut                 |
| 67       | Ref Only    | 1/4-20 x 5/8" Button Head Screw              |
| 68       | Ref Only    | 1/4-20 x 1" Hex Head Screw                   |
| 69       | Ref Only    | 10-32 x 3/16" Cup Point Set Screw            |
| 70       | 40229       | Stabilizer Pad                               |
| 71       | 40222       | Beveled Wheel Assembly w/ Bearings           |
| 72       | 40224       | Wheel Bushing                                |
| 73       | Ref Only    | 1/2-13 x 3" Hex Head Screw                   |
| 74       | Ref Only    | 1/2" Flat Washer                             |
| 75       | Ref Only    | 1/2-13 Hex Nut                               |
| 76       | Ref Only    | 1/8" x 1 1/4" Spring Pin                     |
| 77       | 40219       | Support Channel Weldment                     |
| 78       | 40223       | Slide Bar                                    |

**\*Updated Part-These parts must be replaced as a set in Yellow assemblies.**

## RS4000 Jackson Servo Extension---Part # 40231

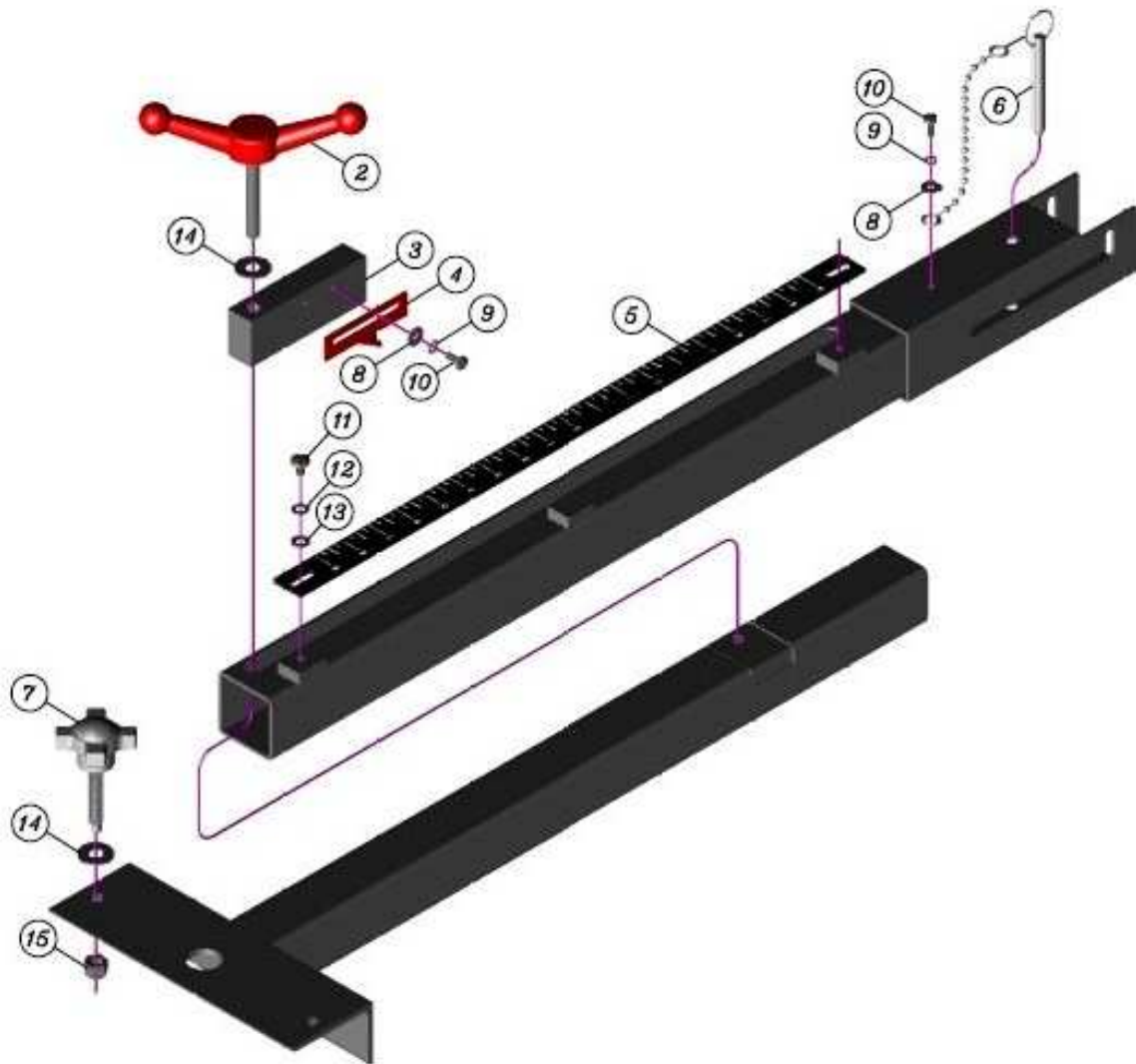

## 40231 Parts List

| <u>Item No.</u> | <u>Part Number</u> | <u>Description</u>                |
|-----------------|--------------------|-----------------------------------|
| 1               | 40231              | Extension Arm Assembly            |
| 2               | 40266              | Knob Assembly                     |
| 3               | 40267              | Clamp Block                       |
| 4               | 40268              | Pointer                           |
| 5               | 40174              | Scale                             |
| 6               | 40263              | Pin                               |
| 7               | 40264              | Knob                              |
| 8               | Ref Only           | #10 Flat Washer                   |
| 9               | Ref Only           | #10 External Tooth Lock Washer    |
| 10              | Ref Only           | 10-32 x 1/2" Pan Head Slot Screw  |
| 11              | Ref Only           | 1/4-20 x 3/8" Pan Head Slot Screw |
| 12              | Ref Only           | 1/4" External Tooth Lock Washer   |
| 13              | Ref Only           | 1/4" Narrow Washer                |
| 14              | Ref Only           | 3/8" Flat Washer                  |
| 15              | Ref Only           | 3/8-16 Lock Nut                   |

**RS4000 Cannon Servo---Part # 40552, 40554,  
40555 & 40556** (Pg 1 of 3)

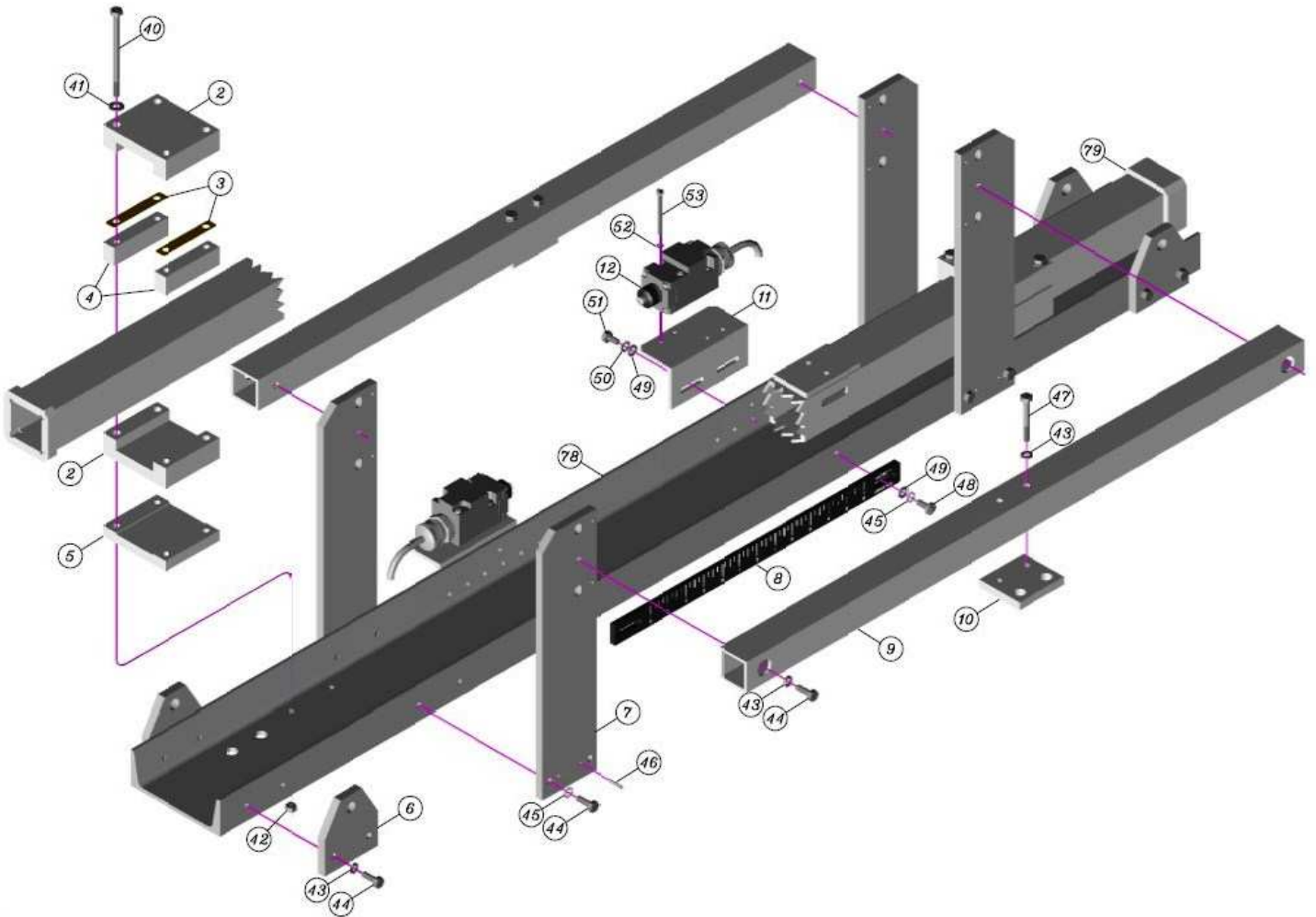

**RS4000 Carron Servo--- Part # 40552, 40554,  
40555 & 40556 (Pg 2 of 3)**

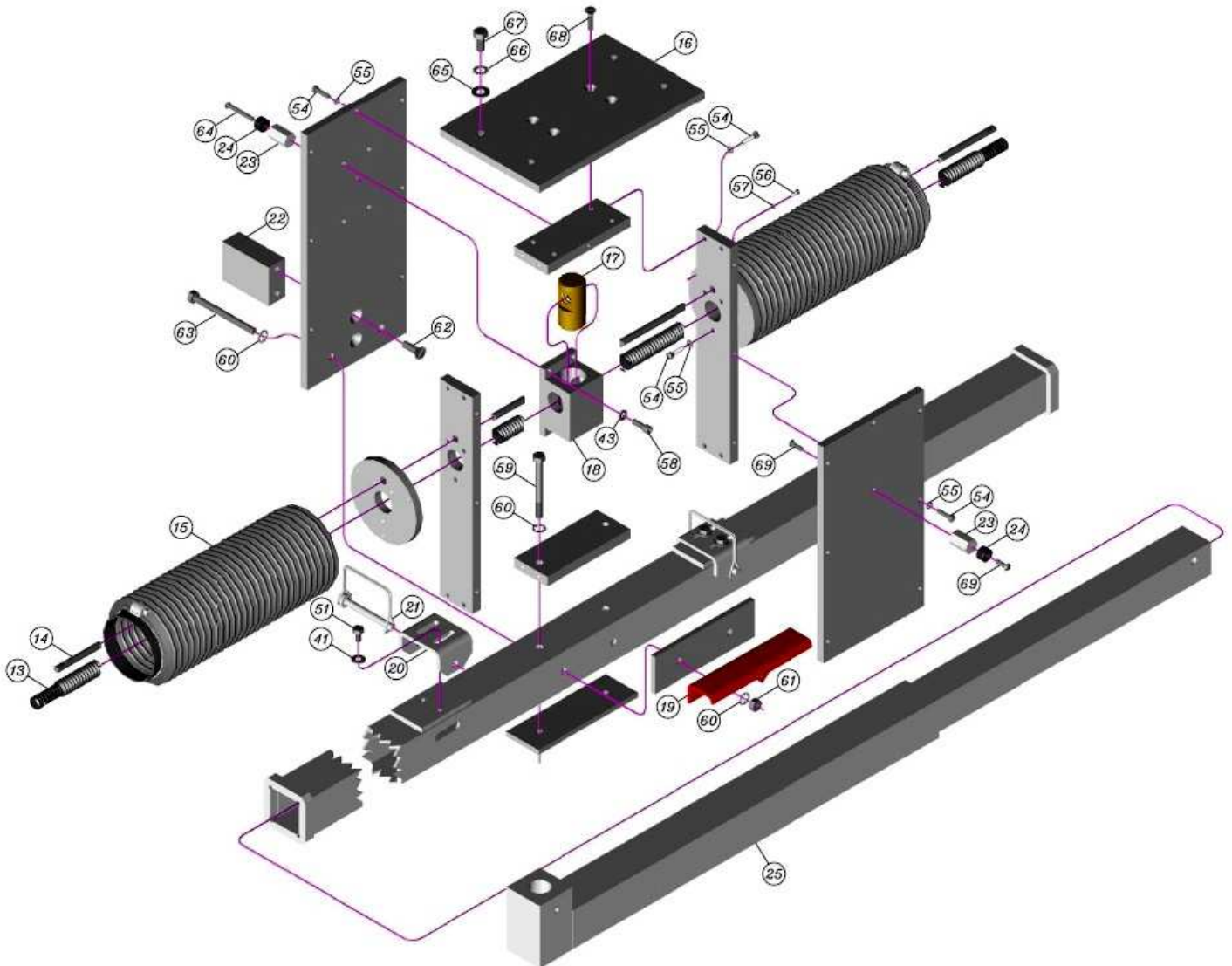



**RS4000 Cannon Servo--- Part # 40552, 40554,  
40555 & 40556** (Pg 3 of 3)

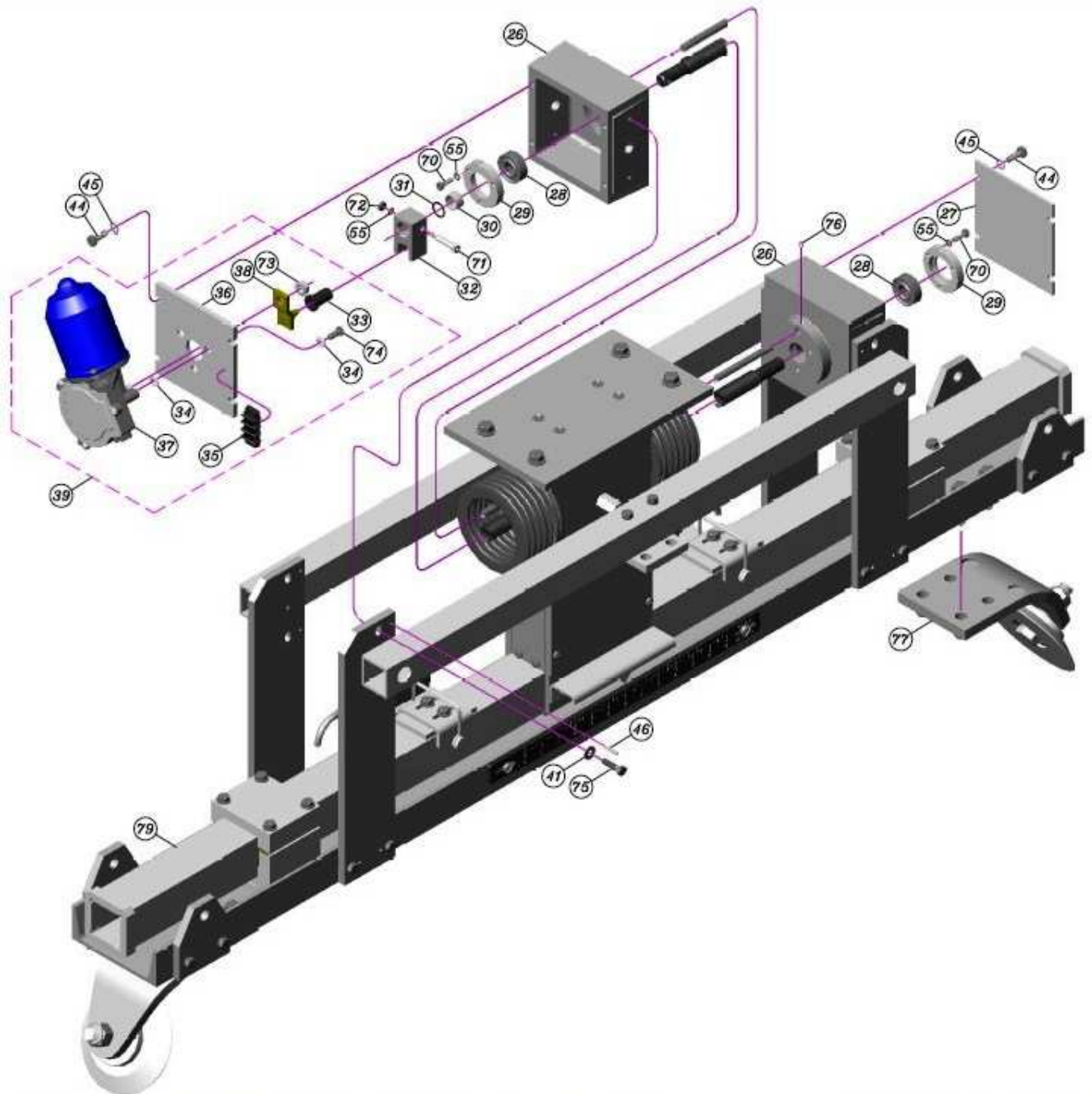

## 40552, 40554, 40555 & 40556 Parts List (Pg 1 of 2)

| Item No. | Part Number | Description                             |
|----------|-------------|---|
| 1        | 40552       | Canron Servo Assembly                   |
| 2        | 40208       | Outer Bearing                           |
| 3        | 40212       | Shim                                    |
| 4        | 40204       | Bearing Spacer                          |
| 5        | 40206       | Bearing Block                           |
| 6        | 40243       | Mounting Bracket                        |
| 7        | 40233       | Drive Support Plate                     |
| 8        | 40370       | Universal Standard/Metric Scale         |
| 9        | 40234       | Guide Rail                              |
| 10       | 40242       | Anchor Plate                            |
| 11       | 40200       | Limit Switch Mounting Bracket           |
| 12       | 40072       | Limit Switch                            |
| 13       | 40173       | Jack Screw*                             |
| 14       | 40213       | Support Rod                             |
| 15       | 40077       | Bellows/Flexible Shield w/ Clamps (SET) |
| 16       | 40191       | Sensor Plate                            |
| 17       | 40172       | Brass Nut*                              |
| 18       | 40203       | Nut Guide                               |
| 19       | 40199       | Pointer Bracket                         |
| 20       | 40247       | Stop Block                              |
| 21       | 40309       | Hitch Pin                               |
| 22       | 40239       | Trip Block                              |
| 23       | 40235       | Standoff                                |
| 24       | 40249       | Plug                                    |
| 25       | 40248       | Extension Arm                           |
| 26       | 40043       | 5X5 Cast Housing                        |
| 27       | 40197       | Cover Plate                             |
| 28       | 40078       | Jack Screw Bearing                      |
| 29       | 40209       | Bearing Retainer                        |
| 30       | 40205       | Bearing Spacer                          |
| 31       | 40271       | Non-Metallic Washer/Shim                |
| 32       | 40227       | Crank Shaft                             |
| 33       | 40226       | Sleeve                                  |
| 34       | 40225       | Non-Metallic Shoulder Washer            |
| 35       | 40085       | Terminal Block                          |
| 36       | 40214       | Motor Mounting Plate                    |
| 37       | 40075       | 24VDC Servo Motor                       |
| 38       | 40076       | Motor Arm                               |
| 39       | 40281       | Servo Motor Assembly w/ Sleeve          |
| 40       | Ref Only    | 1/4-20 x 4" Hex Head Screw              |
| 41       | Ref Only    | 1/4" Flat Washer                        |

## 40552, 40554, 40555 & 40556 Parts List (Pg 2 of 2)

| Item No.     | Part Number | Description                                  |
|--------------|-------------|--|
| 42           | Ref Only    | 1/4-20 Hex Nut                               |
| 43           | Ref Only    | 1/4" Split Ring Lock Washer                  |
| 44           | Ref Only    | 1/4-20 x 3/4" Hex Head Screw                 |
| 45           | Ref Only    | 1/4" Internal Tooth Lock Washer              |
| 46           | Ref Only    | 1/8" x 3/4" Spring Pin                       |
| 47           | Ref Only    | 1/4-20 x 2" Hex Head Screw                   |
| 48           | Ref Only    | 1/4-20 x 5/8" Pan Head Slot Screw            |
| 49           | Ref Only    | 1/4" Flat Washer                             |
| 50           | Ref Only    | 1/4" External Tooth Lock Washer              |
| 51           | Ref Only    | 1/4-20 x 1/2" Hex Head Screw                 |
| 52           | Ref Only    | #10 External Tooth Lock Washer               |
| 53           | Ref Only    | 10-24 x 2" Pan Head Slot Screw               |
| 54           | Ref Only    | 10-24 x 3/4" Pan Head Slot Screw             |
| 55           | Ref Only    | #10 Split Ring Lock Washer                   |
| 56           | Ref Only    | 6-32 x 3/8" Pan Head Slot Screw              |
| 57           | Ref Only    | #6 Split Ring Lock Washer                    |
| 58           | Ref Only    | 1/4-20 x 3/4" Socket Head Screw              |
| 59           | Ref Only    | 5/16-18 x 3" Hex Head Screw                  |
| 60           | Ref Only    | 5/16" Internal Tooth Lock Washer             |
| 61           | Ref Only    | 5/16-18 Hex Nut                              |
| 62           | Ref Only    | 5/16-18 Flat Head Screw                      |
| 63           | Ref Only    | 5/16-18 x 3 1/2" Hex Head Screw              |
| 64           | Ref Only    | 10-32 x 1 1/2" Round Head Screw              |
| 65           | Ref Only    | 3/8" Flat Washer                             |
| 66           | Ref Only    | 3/8" External Tooth Lock Washer              |
| 67           | Ref Only    | 3/8-16 x 3/4" Hex Head Screw                 |
| 68           | Ref Only    | 1/4-20 x 1" Flat Head Screw                  |
| 69           | Ref Only    | 10-32 x 5/8" Round Head Screw                |
| 70           | Ref Only    | 10-32 x 5/8" Hex Head Screw                  |
| 71           | Ref Only    | 10-24 Thd, 1" Long x 1/4" Dia. Shoulder Bolt |
| 72           | Ref Only    | 10-24 Hex Nut                                |
| 73           | Ref Only    | 8mm-1.25 Serrated Flange Nut                 |
| 74           | Ref Only    | 1/4-20 x 5/8" Button Head Screw              |
| 75           | Ref Only    | 1/4-20 x 1" Hex Head Screw                   |
| 76           | Ref Only    | 10-32 x 3/16" Cup Point Set Screw            |
| 77           | 40297       | Beveled Wheel Assembly                       |
| Not Pictured | 40318       | Beveled Wheel Assembly (42" Spec)            |
| 78           | 40241       | Support Channel (39", 42" & 56.5")           |
| 79           | 40246       | Slide Bar                                    |

**\*Updated Part-These parts must be replaced as a set in Yellow assemblies.**

# RS4000 Carron Guide Wheel Assembly---Part # 40297 & 40318

40297---56.5" Beveled Wheel Assembly  
40318---42" Beveled Wheel Assembly

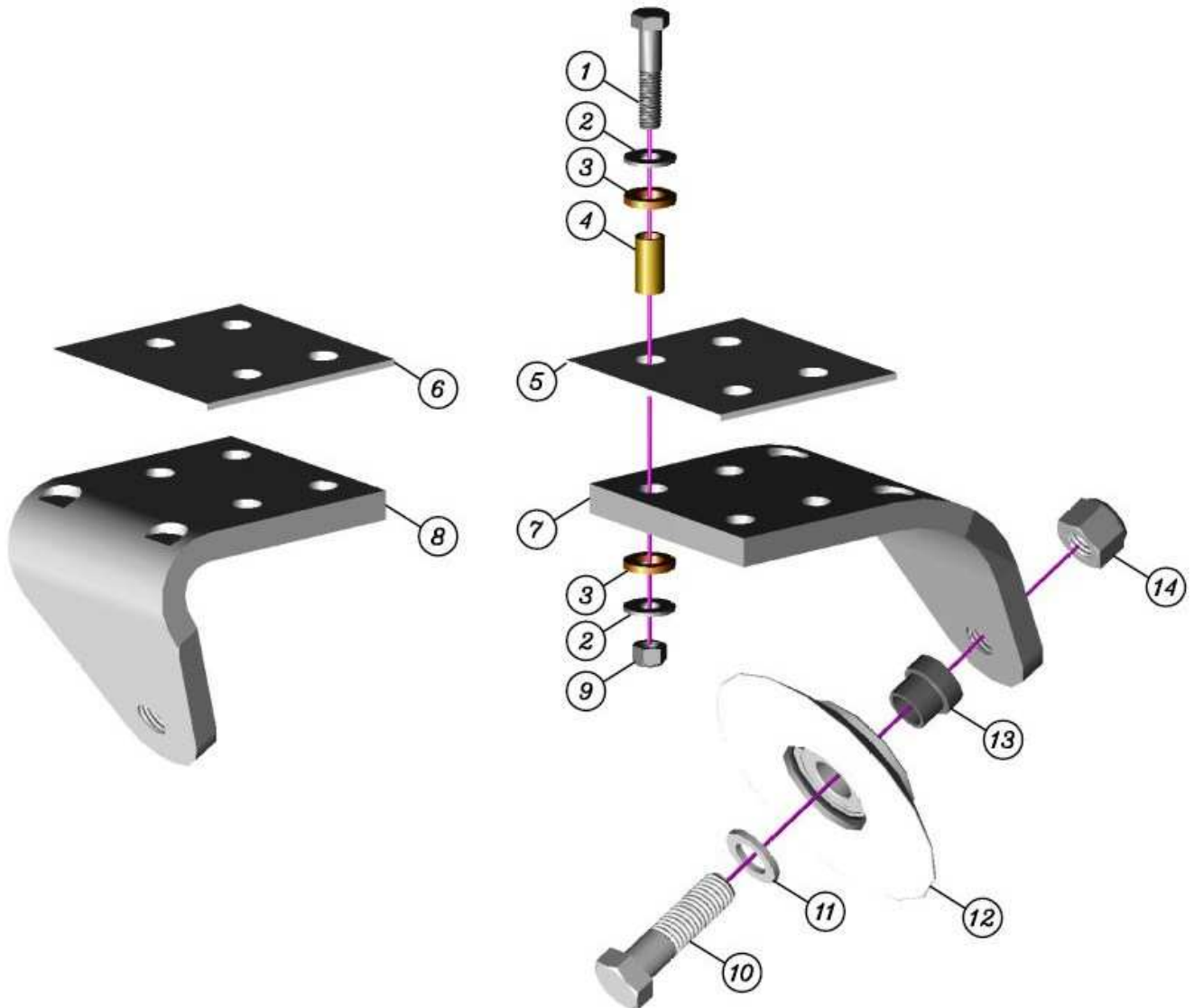

## 40297 & 40318 Parts List

| Item No. | Part Number | Description                       |
|----------|-------------|-----------------------------------|
| 1        | Ref Only    | 3/8-16 x 1-3/4 Hex Head Bolt      |
| 2        | Ref Only    | 5/16 Flat Washer                  |
| 3        | 40306       | Phenolic Isolator, Washer         |
| 4        | 40305       | Phenolic Isolator, Cylinder       |
| 5        | 40304       | UHMW Isolator Pad                 |
| 6        | 40317       | UHMW Isolator Pad (42" Spec)      |
| 7        | 40303       | Wheel Mounting Bracket            |
| 8        | 40316       | Wheel Mounting Bracket (42" Spec) |
| 9        | Ref Only    | 3/8-16 Nylon Lock Nut             |
| 10       | Ref Only    | 5/8-11 x 2-1/4 Hex Head Bolt      |
| 11       | 40301       | Wheel Washer                      |
| 12       | 40307       | Beveled Wheel w/ Bearing          |
| 13       | 40302       | Wheel Bushing                     |
| 14       | Ref Only    | 5/8-11 Nylon Lock Nut             |

## Troubleshooting

| Symptom   | Possible Causes and Solutions   |
|---|---|
| The Laser/Cannon does not turn on.                            | <ul style="list-style-type: none"> <li>• <b>Low or dead battery</b>-Charge Battery</li> <li>• <b>Dirty or corroded contacts</b>-Clean Contacts</li> <li>• <b>Damaged Keybox cable</b>-Replace Keybox Cable</li> <li>• <b>Damaged power cable on the Laser*</b>-Send the Laser in for service</li> </ul> <p><i>*Never attempt to repair the laser on your own. This items contains High Voltage electronic componets. Personal injury or additional equipment damage could result.</i></p>   |
| The Lasers working distance is reduced.                       | <ul style="list-style-type: none"> <li>• <b>Low battery</b>-Charge Battery</li> <li>• <b>Enviornmental conditions are affecting the Laser</b>-Heat shimmer, rain, snow, ice, fog, and dust are all examples of conditions that will affect the working distance of the equipment.</li> <li>• <b>Dirty or obstructed lens on the Laser and/or Sensor</b>-Clean lenses</li> <li>• <b>Laser output is deminished</b>-Send Laser in for service</li> </ul>  |
| The Sensor/Servo will not settle or it is constantly hunting. | <ul style="list-style-type: none"> <li>• <b>The Laser was not properly aligned during set up</b>-Check the Laser and Scope to ensure properly alignment. Send the unit in for calibration if necessary.</li> <li>• <b>Moisture is present on the Lenes of the Laser and/or Sensor</b>-Ensure that the Lenes on the Laser and Sensor are dry and free from obstruction.</li> <li>• <b>System set up issues</b>-It is essential for all of the componets of the system to be set up correctly. There are multiple componets to include the Buggy, Tripod, Laser, and Servo that are either adjustable or have adjustable parts that must be correctly set up. Ensure that none of these items needs attention.</li> <li>• <b>The Sensor is responding to an alternate input</b>-In most cases the Sensor will ignore 'white noise'. However, it is possible that a Sensor facing the sun when it is low enough will incorrectly respond. Shade the Sensor from the sun if the situation applies. If this does not fix the problem, it may be necessary to send the Sensor in for repair.</li> </ul> |
| The Sensor is not responding to the laser.                    | <ul style="list-style-type: none"> <li>• <b>Environmental conditions are affecting the system</b>-Ensure that the Lenes on the Laser and Sensor are dry and free from obstruction. Also ensure that nothing is blocking the sensor from seeing the Laser in the work area.</li> <li>• <b>Improper Laser Set-up</b>-The Tripod that secures the Laser to the Buggy has multiple adjustments. Ensure that the Laser is correctly oriented toward the Sensor.</li> <li>• <b>Fuse Issue</b>-Ensure that fuse F7, F10 and F11 in the Panel are not blown and are making good contact.</li> <li>• <b>Bad connection inside Panel</b>-Ensure that the 'Sensor' connection (J2) is properly seated and clean.</li> <li>• <b>Sensor Cable Damage/Failure</b>- Replace the cable.</li> <li>• <b>Sensor Damage/Failure</b>-Send the Sensor in for Service.</li> </ul>  |

|  |  |
|--|--|
| <p><b>The Panel will not turn on.</b></p>  | <ul style="list-style-type: none"> <li>• <b>Panel power has been interrupted</b>-Ensure that the power cord from the power source to the Panel is not damaged and is properly attached to the power source and Panel. You can test for voltage in the power cord by using a voltage meter set for DC power. Pin A of the connector into the Panel should have 24 VDC, Pin B is the ground.</li> <li>• <b>Fuse Issue</b>-Ensure that fuses F1 &amp; F7 in the Panel are not blown and are making good contact.</li> <li>• <b>Bad connection inside Panel</b>-Ensure that the '24 Volt Input'(J4) connection below fuse F7 and the 'Switches' (J5) connection are properly seated and clean.</li> <li>• <b>Panel Damage/Failure</b>-Send the Panel in for repair.</li> </ul>   |
| <p><b>The Left and/or Right indicator lights on the panel will not turn off.</b></p> <p><b>The Left and/or Right indicator lights on the Lightbar will not turn off. Also, one or both of the Red Limit indicators is illuminated.</b></p> | <ul style="list-style-type: none"> <li>• <b>Missing Limit Switch</b>-The panel is looking for both of the limit switches located on the Servo. If the inputs from one or both of the switches is not present, the Panel will indicate this to you by turning on the corresponding indicator light. In addition the Panel will not function until this input is satisfied. Ensure that both of the limit switches are present, connected properly and are in good working condition.</li> <li>• <b>Limit Switch is engaged</b>-Ensure that the Servo is not completely to one end of travel activating one of the limit switches.</li> <li>• <b>Limit Switch or Cable Damage/Failure</b>-It is also possible that if a limit switch has failed it will appear to be engaged. Replace the limit switch or the cable.</li> <li>• <b>Fuse Issue</b>-Ensure that fuses F4, F5 &amp; F6 in the Panel are not blown and are making good contact.</li> </ul> |
| <p><b>The Left, Center or Right indicator lights on the Panel will not turn on.</b></p> <p><b>The Left, Center or Right indicator lights on the Lightbar will not turn on.</b></p>   | <ul style="list-style-type: none"> <li>• <b>Fuse Issue</b>- Ensure that fuses F1, F2 &amp; F3 in the Panel are not blown and are making good contact.</li> <li>• <b>Indicator Damage/Failure</b>-Send the Panel in for repair.</li> </ul>  |
| <p><b>The Standby indicator light on the Panel will not turn on.</b></p>   | <ul style="list-style-type: none"> <li>• <b>Fuse Issue</b>- Ensure that fuse F12 in the Panel is not blown and is making good contact.</li> <li>• <b>Indicator Damage/Failure</b>-Send the Panel in for repair</li> </ul>  |
| <p><b>The Power indicator light on the Panel will not turn on.</b></p>   | <ul style="list-style-type: none"> <li>• <b>Fuse Issue</b>- Ensure that fuses F8 in the Panel is not blown and is making good contact.</li> <li>• <b>Indicator Damage/Failure</b>-Send the Panel in for repair</li> </ul>  |
| <p><b>The Limit indicator lights on the Lightbar will not turn on when the Servo reaches its limits.</b></p>   | <ul style="list-style-type: none"> <li>• <b>Fuse Issue</b>- Ensure that fuses F6 in the Panel is not blown and is making good contact.</li> <li>• <b>Indicator Damage/Failure</b>-Send the Panel in for repair</li> </ul>  |

|  |   |
|--|---|
| <p><b>The Lightbar does not function.</b></p>  | <ul style="list-style-type: none"> <li>• <b>Lightbar power has been interrupted</b>-Ensure that the cord from the Lightbar to the Panel is not damaged and is properly attached to the Lightbar and Panel. Replace cable if damaged.</li> <li>• <b>Fuse Issue</b>-Ensure that fuses F1, F2, F3 &amp; F6 in the Panel are not blown and are making good contact.</li> <li>• <b>Bad connection inside Panel</b>-Ensure that the 'Lightbar' connection (J10) is properly seated and clean.</li> <li>• <b>Lightbar Damage/Failure</b>-Send the Lightbar in for repair.</li> </ul>   |
| <p><b>The Servo does not function.</b></p>   | <ul style="list-style-type: none"> <li>• <b>Servo power has been interrupted</b>-Ensure that the cord from the Servo to the Panel is not damaged and is properly attached to the Servo and Panel. You can test for voltage in the power cord by using a voltage meter set for DC power. You should see +/- 24 VDC between the motor leads. Use the Manual Left/Right switch on the Panel to energize the circuit for this test.</li> <li>• <b>Motor Damage/Failure</b>-Replace the servo motor.</li> <li>• <b>No signal from the Sensor</b>-If the Servo responds to the manual Left/Right switch on the Panel, refer to 'The Sensor is not responding to the Laser' above.</li> <li>• <b>Fuse Issue</b>-Ensure the fuse F13 in the Panel is not blown and is making good contact.</li> <li>• <b>Bad connection inside the Panel</b>-Ensure that the 'Motor' connection (J3) is properly seated and clean.</li> <li>• <b>Servo Damage/Failure</b>-Send the Servo in for repair.</li> </ul>  |
| <p><b>The Servo will not move in one direction.</b></p>  | <ul style="list-style-type: none"> <li>• <b>Limit Switch is Activated</b>-Check to ensure that the Servo is not at its travel limit in the direction you want it to move. If it is, you should have a Red Limit light illuminated on your Lightbar. If you are trying to get the servo to move off of a limit switch but it will not respond, it may be because the limit switches are reversed. This is easily figured out by determining if the Servo motor is still attempting to drive the Servo in the direction that the limit switch that appears to be activated. Activate the opposite side limit switch and see if the power to the motor is cut. Switch the limit switch connections on the Panel if this is the problem.</li> <li>• <b>No signal from the Sensor</b>-If the Servo responds to the manual Left/Right switch on the Panel, refer to 'The Sensor is not responding to the Laser' above.</li> <li>• <b>Fuse Issue</b>-Ensure that fuses F4 and F5 in the Panel are not blown and are making good contact.</li> <li>• <b>Bad connection inside the Panel</b>-Ensure that the 'Motor' connection (J3) is properly seated and clean.</li> <li>• <b>Servo Damage/Failure</b>-Send the Servo in for repair.</li> </ul> |
| <p><b>System acts 'Nervous' all the time and I have swapped out several components in an attempt to try and pinpoint the issue with no change in behavior from the system.</b></p> | <ul style="list-style-type: none"> <li>• <b>'Dirty' Supply Power</b>- We have found that with some tampers, there is a lot of 'noise' in the supply power and/or traveling on the ground. If this noise is extremely bad, it can cause the RS4000 system to act very nervous. It may be necessary to filter the supply power with a good line conditioner to correct this problem.</li> </ul>   |



**Product Identification**

The Rail System 4000 product model numbers listed below each have an external identification label on them. Enter the serial numbers below along with the purchase dates. Retain this information for your records, refer to it when you need to contact us with questions or concerns.

|                          | Serial # | Purchase Date |
|--------------------------|----------|---------------|
| Panel Model # 40500      | _____    | _____         |
| Lightbar Model # 40510   | _____    | _____         |
| Sensor Model # 40520     | _____    | _____         |
| Laser Model # 40530/3    | _____    | _____         |
| Solar Cart Model # 40546 | _____    | _____         |

**Warranty**

Rail Alignment LLC (Rail Alignment) warrants to the original end user (Customer) that this product will be free from defects in workmanship and materials under normal use, and provided any and all operating and maintenance instructions are strictly respected, in particular in case of extreme and/or continuous applications/use of the product. Any evidence of an attempt to repair a Rail System 4000 (RS4000) component by other than factory authorized personnel using Rail Alignment certified replacement parts will automatically void the warranty.

Rail Alignments liability under this warranty is limited to repairing or replacing any product returned to a factory authorized service facility for that purpose. The foregoing states the entire liability of Rail Alignment in connection with the RS4000 components, and they shall not be held responsible for any consequential damage of any kind. The foregoing is in lieu of all other warranties expressed or implied.

The user of the RS4000 components is expected to follow all operating instructions, periodically checking the components and the work as it progresses. Checking and ensuring the calibration of the system and/or its components is the responsibility of the user. Calibration and maintenance is not covered by the above warranty.

**Warranty Period:** 12 months from date of purchase from Rail Alignment.

**Laser Specialists, Inc**

19879 W 156<sup>th</sup> St

Olathe KS 66062

PH: 913 780 9990

FX: 913 780 9815

*....The only factory authorized service center for all of your Rail System 4000 components!*

## **Calibration**

The RS4000 components are calibrated to the defined accuracy specifications at the factory, except where customer assembly is required. It is recommended to check your RS4000 components for calibration periodically before using them to ensure calibration is maintained. If any factory set items require calibration, send them to your nearest authorized service center.

Do not attempt component calibration unless you plan to change the calibration. Calibration should be performed only by a qualified individual that understands basic calibration principles.

## **Transport**

When transporting the various components of the RS4000, always use the complete original Rail Alignment packaging (case and/or cardboard box).

When transporting the Laser in the field, always make sure that you carry it in its carrying case.

When transporting RS4000 components by rail, air, ship or motor vehicle, always use the complete original packaging (case and/or cardboard box), or its equivalent to protect it against damage from impact, shock and vibration.

After transport, or after long periods of storage, inspect each RS4000 component for damage and proper functionality. Remove any RS4000 components from service and contact your service provider if you find that any of your equipment has been damaged or does not function properly.

## **Storage**

Temperature Limits -40° to 158°F (-40° to 70°C). Respect the temperature limits when storing the components, particularly in summer if the components are in a non-climate controlled enclosure.

Damp components must be unpacked. Dry the components, the case and any accessories at not more than 108°F and clean them. Do not repack until everything is completely dry.

## **Cleaning and Drying Windows**

Never touch windows with your fingers. Use only a clean, soft, lint-free cloth for cleaning. If necessary, moisten the cloth with water or pure alcohol. Use no other liquids; these may attack the polymer components and cause failure.

## **Maintenance**



**Warning:** Only Rail Alignment authorized workshops are entitled to repair these products. DO NOT ATTEMPT TO OPEN THE LASER ASSEMBLY.

*Continued next page*

It is the user's responsibility each time the laser is set up, to visually inspect the laser housing to verify that it has not been damaged so as to allow access to laser light from the interior of the laser from any place other than its intended source. If damage to the laser or a malfunction is present, discontinue use of the equipment and return it to your nearest service center for repair.

### **Safety/Responsibilities**



**Caution:** Use of controls or adjustments or performance of procedures other than those specified herein may result in hazardous laser light exposure.



**Warning:** HeNe laser power up to 4.75mW is emitted through the laser window.

Rail Alignment is responsible for supplying the product, including the user manual and original accessories in a completely-safe condition.

The manufacturers of non-Rail Alignment accessories for any RS4000 components and or equipment controlled by the RS4000 system, are responsible for developing, implementing and communicating safety concepts for their products, and are also responsible for the effectiveness of those safety concepts in combination with Rail Alignment product.

The person responsible for the RS4000 equipment must ensure that it is used in accordance with the instructions. This person is also accountable for the training and the deployment of personnel who use the instrument and for the safety of the equipment in use.

The person in charge of the equipment has the following duties:

- To understand the safety instructions on the product and the instructions in the user manual.
- To inform Rail Alignment immediately if the equipment becomes unsafe.



**Warning:** Adverse use can lead to injury, malfunction, and material damage. It is the task of the person responsible for the RS4000 equipment to inform the user about hazards and how to counteract them. The RS4000 equipment is not to be used until the user has been instructed how to work with it. All users must follow the safety directions given by the manufacturer and the directions of the person responsible for the equipment.

### **Laser Classification**



**Warning:** Avoid possible exposure to laser light.

**Class 3R Laser:** Class 3R lasers are considered safe if handled correctly, with restricted beam viewing and maintained in accordance with the instructions. Changes or modifications not expressly approved by Rail Alignment could void the user's authority to operate this equipment.

**Illustration of the Safety Decals Affixed to the front of the Laser--**



**FCC Statement**

This equipment complies with limits for a Class A digital device, pursuant to part 15 of the FCC rules.

This device complies with Part 15 of the FCC Rules. Operation is subject to the following conditions: (1) This device may not cause harmful interference, and (2) this device must accept any interference received, including interference that may cause undesired operation.



**Warning:** Changes or modifications not expressly approved by Rail Alignment could void the user's authority to operate the equipment.

**Copyright Notice**

Copyright 2016 by Rail Alignment LLC. All rights reserved.

Rail Alignment Proprietary Information

NOTICE: The information/data contained herein is proprietary information of Rail Alignment LLC and is furnished for your controlled use, and shall not be copied or otherwise reproduced, nor in any manner disclosed to any third party, without Rail Alignment's prior written consent. Manual is subject to return on demand. The information in this manual supersedes all previous versions.